

# **Application Manual**

## **OV-0100-C7 Medical**

### **Low Power Clock Oscillator 100.000 kHz**

**TABLE OF CONTENTS**

<b>1. OVERVIEW</b> .....	<b>3</b>
<b>1.1. GENERAL DESCRIPTION</b> .....	<b>3</b>
<b>1.2. APPLICATIONS</b> .....	<b>3</b>
<b>1.3. ORDERING INFORMATION</b> .....	<b>4</b>
<b>2. BLOCK DIAGRAM</b> .....	<b>5</b>
<b>2.1. PINOUT</b> .....	<b>5</b>
<b>2.2. PIN DESCRIPTION</b> .....	<b>5</b>
<b>2.3. DEVICE PROTECTION DIAGRAM</b> .....	<b>6</b>
<b>3. ELECTRICAL SPECIFICATIONS</b> .....	<b>7</b>
<b>3.1. ABSOLUTE MAXIMUM RATINGS</b> .....	<b>7</b>
<b>3.2. OPERATING PARAMETERS</b> .....	<b>7</b>
<b>3.3. TYPICAL CHARACTERISTICS</b> .....	<b>8</b>
<b>3.4. TIMING WAVEFORMS</b> .....	<b>8</b>
<b>3.5. OSCILLATOR PARAMETERS</b> .....	<b>9</b>
3.5.1. XTAL FREQUENCY VS. TEMPERATURE CHARACTERISTICS .....	<b>9</b>
<b>4. PACKAGE</b> .....	<b>10</b>
<b>4.1. DIMENSIONS AND SOLDER PAD LAYOUT</b> .....	<b>10</b>
4.1.1. RECOMMENDED THERMAL RELIEF .....	<b>10</b>
<b>4.2. MARKING AND PIN #1 INDEX</b> .....	<b>11</b>
<b>5. MATERIAL COMPOSITION DECLARATION &amp; ENVIRONMENTAL INFORMATION</b> .....	<b>12</b>
<b>5.1. HOMOGENOUS MATERIAL COMPOSITION DECLARATION</b> .....	<b>12</b>
<b>5.2. MATERIAL ANALYSIS &amp; TEST RESULTS</b> .....	<b>13</b>
<b>5.3. RECYCLING MATERIAL INFORMATION</b> .....	<b>14</b>
<b>5.4. ENVIRONMENTAL PROPERTIES &amp; ABSOLUTE MAXIMUM RATINGS</b> .....	<b>15</b>
<b>6. APPLICATION INFORMATION</b> .....	<b>16</b>
<b>6.1. OPERATING OV-0100-C7 MEDICAL</b> .....	<b>16</b>
<b>6.2. SOLDERING INFORMATION</b> .....	<b>17</b>
<b>6.3. HANDLING PRECAUTIONS FOR MODULES WITH EMBEDDED CRYSTALS</b> .....	<b>18</b>
<b>7. PACKING &amp; SHIPPING INFORMATION</b> .....	<b>19</b>
<b>8. COMPLIANCE INFORMATION</b> .....	<b>20</b>
<b>9. DOCUMENT REVISION HISTORY</b> .....	<b>20</b>

## OV-0100-C7 Medical

### Low Power Clock Oscillator 100.000 kHz

#### 1. OVERVIEW

- Oscillator with built-in “Tuning Fork” crystal oscillating at 100.000 kHz
- Very tight frequency tolerance:  $\pm 20$  ppm
- Excellent oscillator stability:  $< 1.5$  ppm/V
- High shock and vibration resistance
- Wide operating voltage range: 1.2 V to 5.5 V
- Very low power consumption: typ. 650 nA
- Standard operating temperature range  $T_A$ : -40 to +85°C
- CLKOUT enable/disable
- Low aging rate
- Miniature ceramic SMT package, RoHS-compliant and 100% lead-free: 3.2 x 1.5 x 1.0 mm

#### 1.1. GENERAL DESCRIPTION

The OV-0100-C7 Medical combines an advanced very low power CMOS oscillator circuitry together with a 100.000 kHz “tuning-fork” crystal in a miniaturized ceramic package. No external components are required. The very low power consumption over a wide supply voltage and temperature range is the key feature of this product.

The frequency output on CLKOUT pin can be enabled/disabled by the CLKOE pin. The CLKOUT frequency is enabled when CLKOE pin is connected to  $V_{DD}$ . When the CLKOE pin is tied to GND the frequency is disabled and the CLKOUT pin is high impedance (Hi-Z).

The OV-0100-C7 Medical Low Frequency Oscillator is manufactured specifically for use in implantable medical devices.

#### 1.2. APPLICATIONS

The OV-0100-C7 Medical oscillator module combines Medical Implantable Key Features with outstanding performance in a very small ceramic package:

- Smallest oscillator module (embedded XTAL) in a very small 3.2 x 1.5 x 1.0 mm lead-free ceramic package
- Safe for Helium environment: Ceramic lid with gold-tin preform-seal for best long-term hermeticity and stability

These unique features make this product perfectly suitable for many medical applications:

- Pacemakers / Defibrillators / Neurostimulators / Cardiac Monitoring Devices / Implantable Drug Delivery Pumps / Infusion Pumps / Cochlear Implants / Smart Orthopedic Implants / Glucose Meter / Health Monitoring Systems

**1.3. ORDERING INFORMATION**

Example: OV-0100-C7\* T1 -20/+20ppm TA QM

Code	Pads
T1	Au flashed pads
T2	SnPb plated pads on request
T5	ENEPIG plated pads

Code	Operating temperature range
TA	-40 to +85°C

Code	Qualification
QM	Medical Grade

\* The term Medical does not appear in the ordering information. QM implies medical.

## 2. BLOCK DIAGRAM

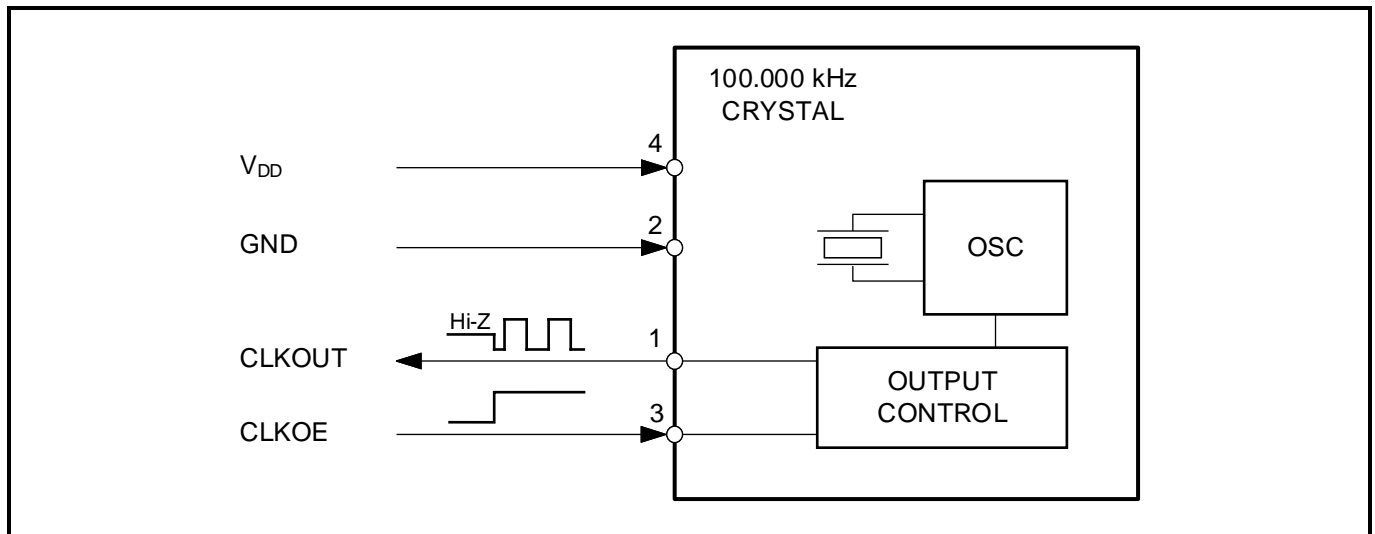

### 2.1. PINOUT

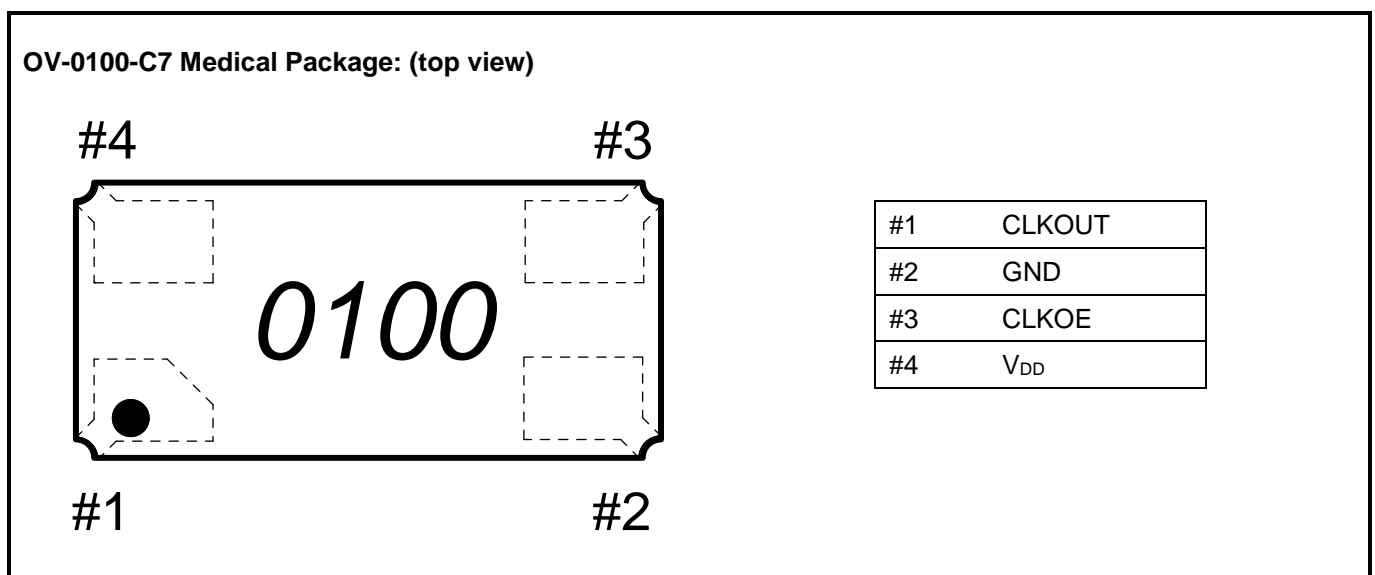

### 2.2. PIN DESCRIPTION

Symbol	Pin #	Description
CLKOUT	1	Clock Output; push-pull; controlled by CLKOE. If CLKOE is HIGH (V <sub>DD</sub> ), the CLKOUT pin drives the square wave of 100.000 kHz. When CLKOE is tied to Ground, the CLKOUT pin is high impedance (Hi-Z).
GND	2	Ground.
CLKOE	3	Input to enable the CLKOUT pin. If CLKOE is HIGH, the CLKOUT pin is in output mode. When CLKOE is tied to Ground, the CLKOUT pin is high impedance (Hi-Z).
V <sub>DD</sub>	4	Power Supply Voltage.

2.3. DEVICE PROTECTION DIAGRAM

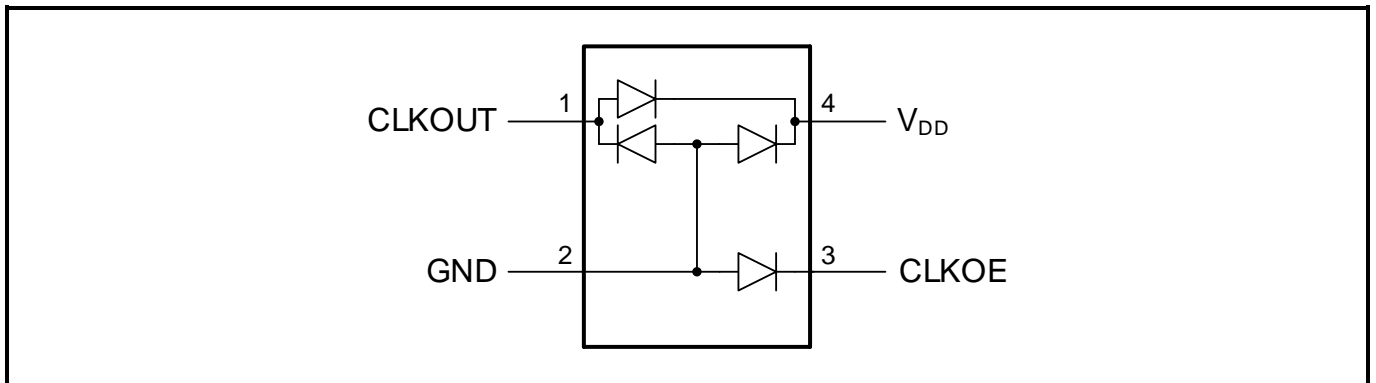

### 3. ELECTRICAL SPECIFICATIONS

#### 3.1. ABSOLUTE MAXIMUM RATINGS

Absolute Maximum Ratings according to IEC 60134:

SYMBOL	PARAMETER	CONDITIONS	MIN	MAX	UNIT
V <sub>DD</sub>	Power supply voltage		-0.5	6.0	V
V <sub>I</sub>	Input voltage		-0.5	6.0	V
V <sub>O</sub>	Output voltage		-0.5	V <sub>DD</sub> +0.5	V
T <sub>OPRA</sub>	Standard operating temperature T <sub>A</sub>		-40	85	°C
T <sub>STO</sub>	Storage temperature	Stored as bare product	-55	125	°C
T <sub>PEAK</sub>	Maximum reflow condition	JEDEC J-STD-020C		265	°C

#### 3.2. OPERATING PARAMETERS

For this Table, V<sub>DD</sub> = 1.2 to 5.5 V; GND = 0V; T<sub>A</sub> = -40 °C to +85 °C; TYP values at 25 °C and 3.0 V; unless otherwise indicated.

Operating Parameters:

SYMBOL	PARAMETER	CONDITIONS	MIN	TYP	MAX	UNIT
<b>Supply</b>						
V <sub>DD</sub>	Power supply voltage		1.2		5.5	V
V <sub>DDSR</sub>	V <sub>DD</sub> slew rate				±0.5	V/ms
I <sub>DD</sub>	V <sub>DD</sub> Supply Current. CLKOUT disabled. <sup>(1)</sup>	V <sub>DD</sub> = 3.0 V, T <sub>OPR</sub> = 25°C		650	850	nA
		V <sub>DD</sub> = 5.0 V, T <sub>OPR</sub> = 25°C		1100	1700	
		V <sub>DD</sub> = 3.0 V, T <sub>A</sub> = -40 to 85°C			1700	
		V <sub>DD</sub> = 5.0 V, T <sub>A</sub> = -40 to 85°C			3400	
<b>Input CLKOE</b>						
V <sub>I</sub>	Input voltage		GND -0.5		V <sub>DD</sub> +0.5	V
V <sub>IL</sub>	LOW level input voltage		GND		0.2 V <sub>DD</sub>	V
V <sub>IH</sub>	HIGH level input voltage		0.8 V <sub>DD</sub>		V <sub>DD</sub>	V
<b>Output CLKOUT</b>						
V <sub>OH</sub>	HIGH level output voltage	I <sub>OH</sub> = -400 µA, V <sub>DD</sub> = 1.5 to 5.5 V	V <sub>DD</sub> -0.4			V
V <sub>OL</sub>	LOW level output voltage	I <sub>OL</sub> = 400 µA, V <sub>DD</sub> = 1.5 to 5.5 V			GND +0.4	V
C <sub>L</sub>	Output load capacitance	CMOS			15	pF
t <sub>r</sub> / t <sub>f</sub>	Rise time / Fall time	C <sub>L</sub> =10 pF, V <sub>DD</sub> = 1.2 to 1.5 V			150	ns
		C <sub>L</sub> =10 pF, V <sub>DD</sub> = 1.5 to 5.5 V			100	ns
t <sub>CKH</sub>	CLKOUT enable time (see following diagram)				0	µs
t <sub>CKL</sub>	CLKOUT disable time (see following diagram)		0		5	µs
<sup>(1)</sup> When CLKOUT is enabled (CLKOE is HIGH) the additional V <sub>DD</sub> supply current ΔI <sub>DD</sub> can be calculated as follows: ΔI <sub>DD</sub> = C <sub>L</sub> x V <sub>DD</sub> x f <sub>OUT</sub> e.g. ΔI <sub>DD</sub> = 10 pF x 3.0 V x 100'000 Hz = 3 µA						

### 3.3. TYPICAL CHARACTERISTICS

Supply current  $I_{DD}$  vs. Supply voltage  $V_{DD}$ :  $T_{OPR} = 25^{\circ}\text{C}$ , CLKOUT disabled

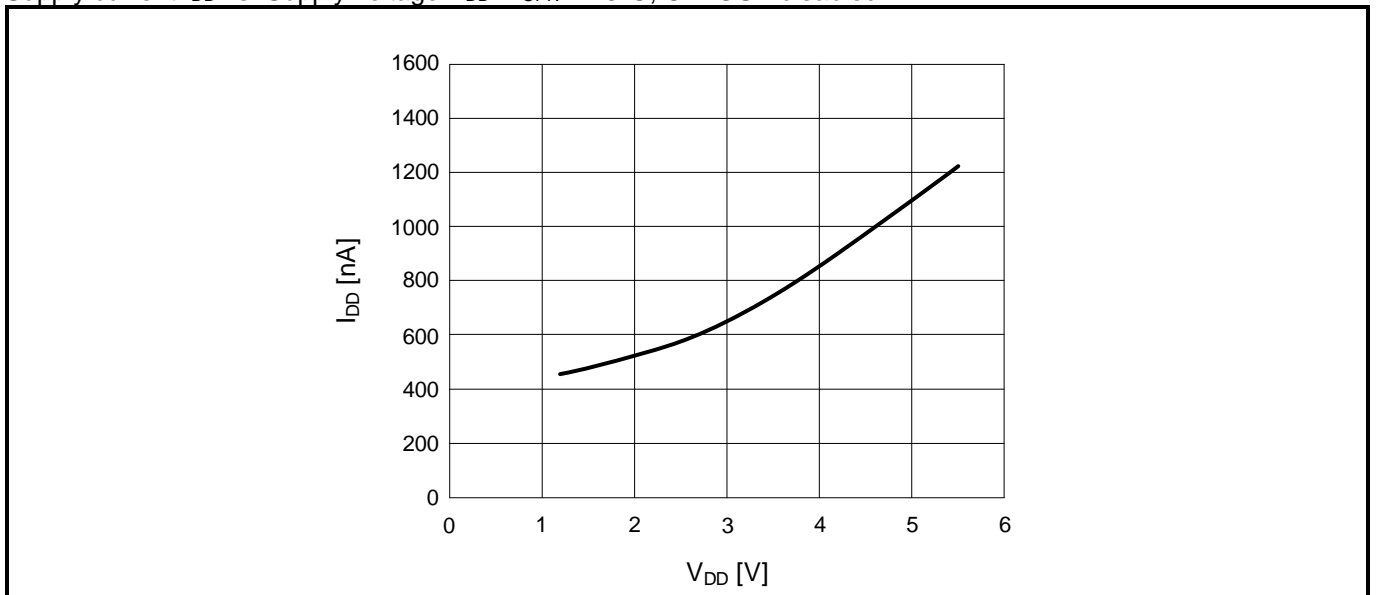

### 3.4. TIMING WAVEFORMS

CLKOUT enable/disable times:

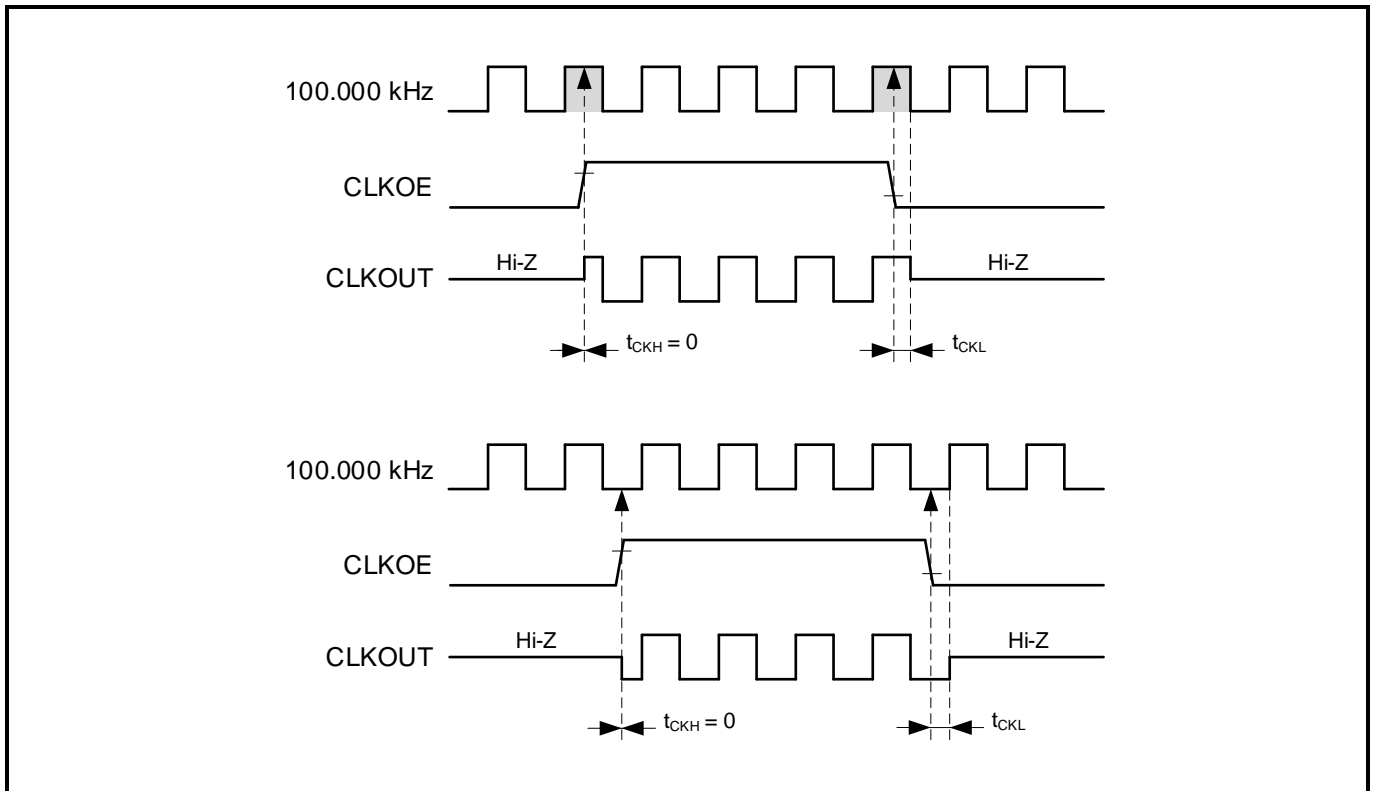



### 3.5. OSCILLATOR PARAMETERS

For this Table,  $V_{DD} = 3.0\text{ V}$ ;  $GND = 0\text{ V}$ ;  $T_{OPR} = 25\text{ }^\circ\text{C}$ , unless otherwise indicated.

Oscillator Parameters:

SYMBOL	PARAMETER	CONDITIONS	MIN	TYP	MAX	UNIT
<b>Xtal General</b>						
f	Crystal Frequency			100.000		kHz
t <sub>START</sub>	Oscillator start-up time			150	500	ms
$\bar{d}_{CLKOUT}$	CLKOUT duty cycle		40		60	%
<b>Xtal Frequency Characteristics</b>						
$\Delta f/f$	Frequency accuracy			$\pm 10$	$\pm 20$	ppm
$\Delta f/V$	Frequency vs. voltage characteristics	$1.2\text{ V} \leq V_{DD} \leq 5.5\text{ V}$			$\pm 1.5$	ppm/V
$\Delta f/f_{TOPR}$	Frequency vs. temperature characteristics	$T_{OPR} = -40^\circ\text{C to } +85^\circ\text{C}$ $V_{DD} = 3.0\text{ V}$		$-0.035\text{ ppm}/^\circ\text{C}^2 (T_{OPR}-T_0)^2 \pm 10\%$		ppm
T <sub>0</sub>	Turnover temperature		13	18	23	°C
$\Delta f/f$	Aging first year max.				$\pm 2$	ppm

#### 3.5.1.XTAL FREQUENCY VS. TEMPERATURE CHARACTERISTICS

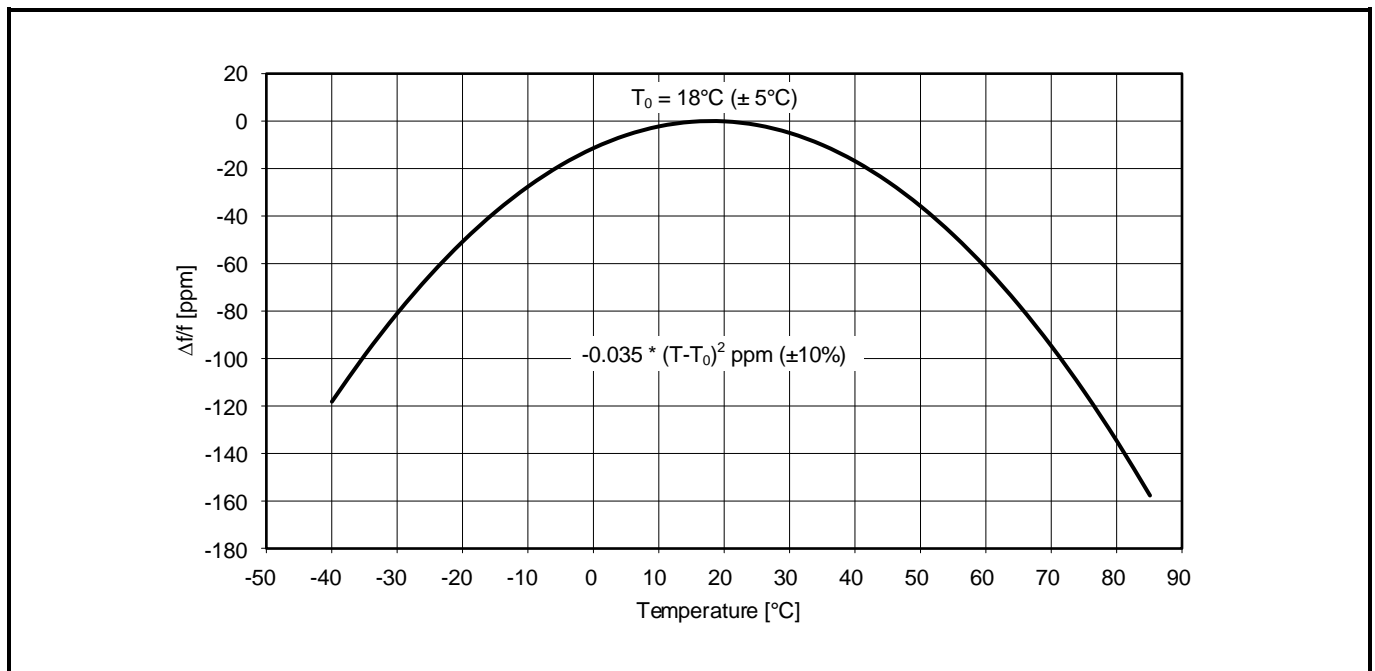

## 4. PACKAGE

### 4.1. DIMENSIONS AND SOLDER PAD LAYOUT

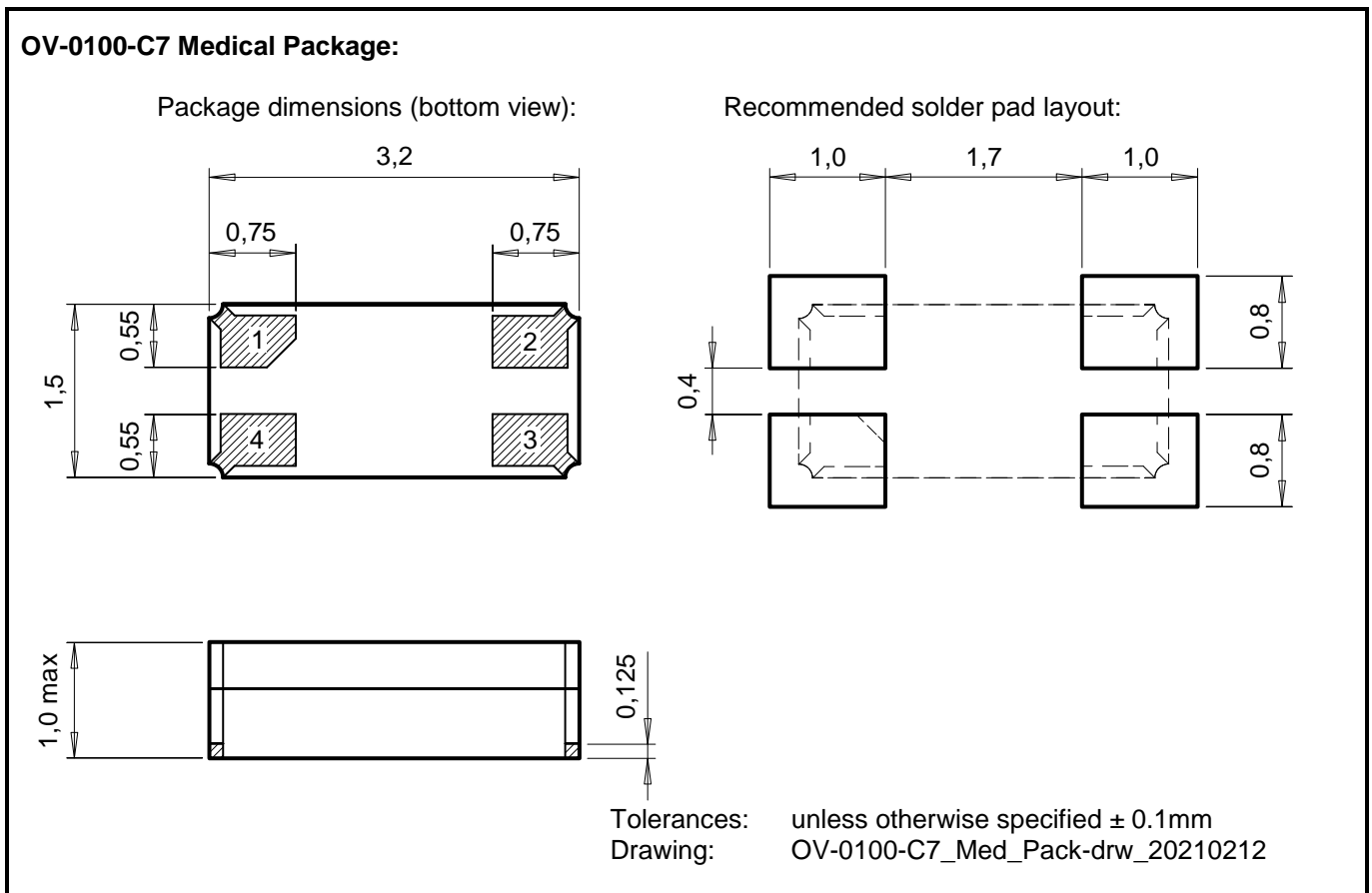

All dimensions in mm typical.

#### 4.1.1. RECOMMENDED THERMAL RELIEF

When connecting a pad to a copper plane, thermal relief is recommended.

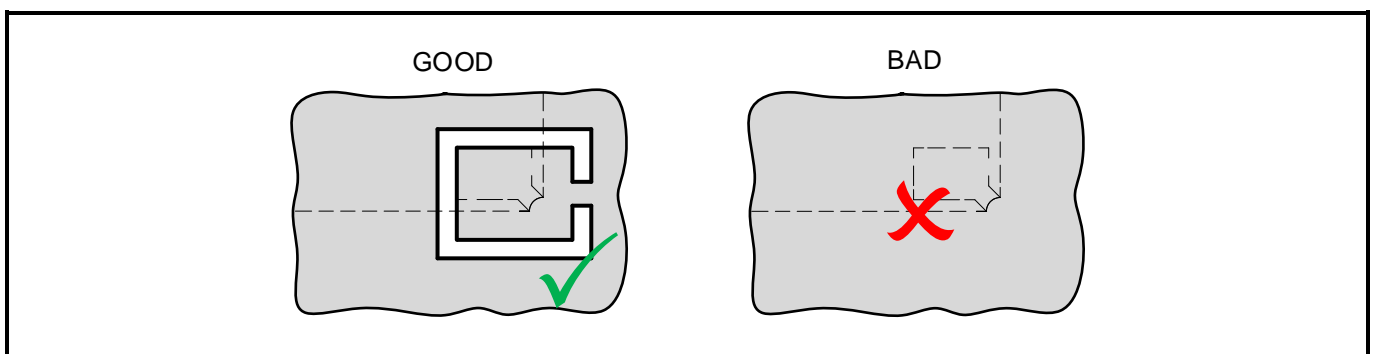

#### 4.2. MARKING AND PIN #1 INDEX

Laser marking OV-0100-C7 Medical Package: (top view)

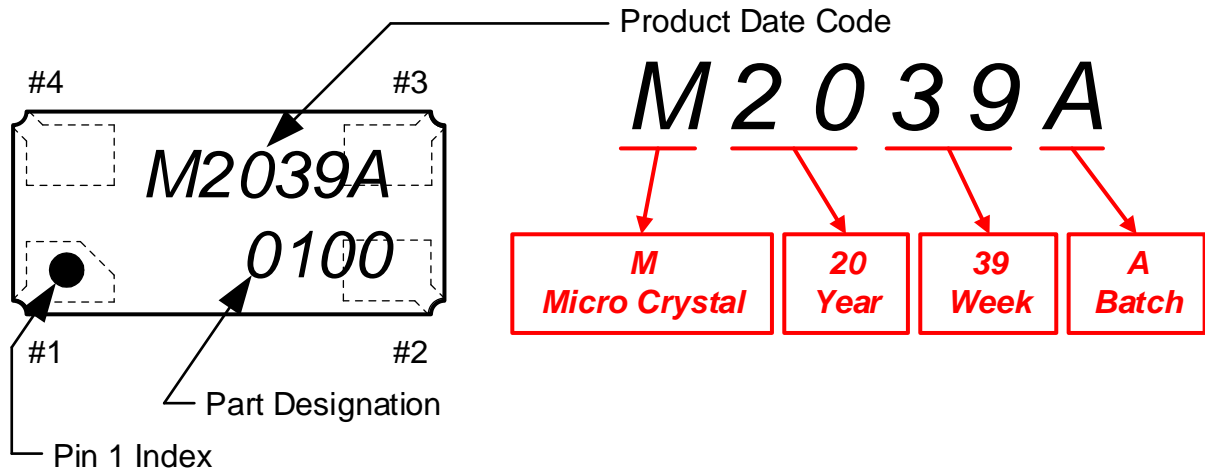

## 5. MATERIAL COMPOSITION DECLARATION & ENVIRONMENTAL INFORMATION

### 5.1. HOMOGENOUS MATERIAL COMPOSITION DECLARATION

Homogenous material information according to IPC-1752 standard

Material Composition OV-0100-C7 Medical:

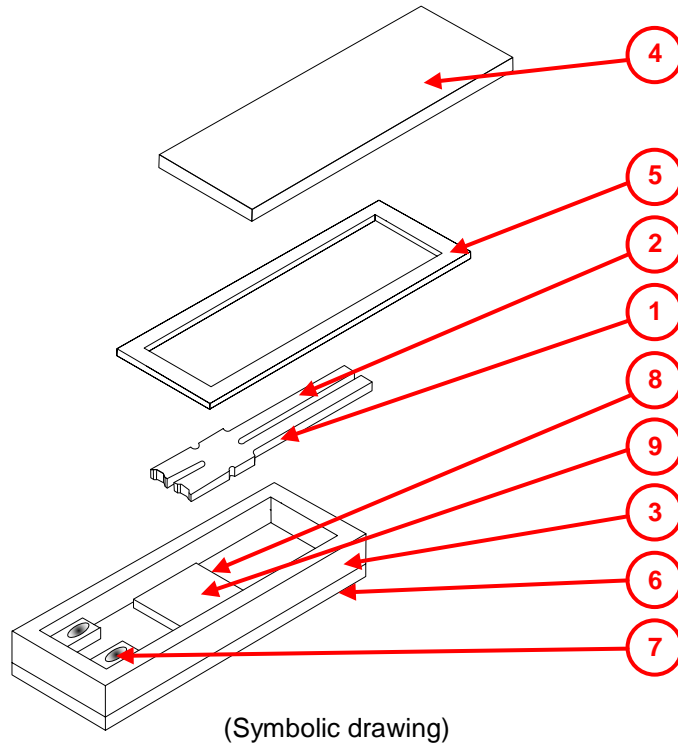

No.	Item Component Name	Sub Item Material Name	Material Weight		Substance Element	CAS Number	Comment
			(mg)	(%)			
1	Resonator	Quartz Crystal	0.40	100%	SiO <sub>2</sub>	14808-60-7	
2	Electrodes	Cr+Au	0.007	5%	Cr	Cr: 7440-47-3	
				95%	Au	Au: 7440-57-5	
3	Housing	Ceramic	6.30	100%	Al <sub>2</sub> O <sub>3</sub>	1344-28-1	
4	Lid	Ceramic	4.65	98.5%	Al <sub>2</sub> O <sub>3</sub>	1344-28-1	Ceramic Lid
				1.0%	Ni	Ni: 7440-02-0	Nickel plating
				0.5%	Au	Au: 7440-57-5	Gold plating
5	Seal	Solder Preform	0.38	80%	Au80 / Sn20	Au: 7440-57-5	
				20%		Sn: 7440-31-5	
6	Terminations	Internal and external terminals	0.33	80%	Mo	Mo: 7439-98-7	Molybdenum
				15%	Ni	Ni: 7440-02-0	Nickel plating
				5%	Au 0.5 micron	Au: 7440-57-5	Gold plating
7	Conductive adhesive	Silver filled Epoxy	0.15	70%	Ag	Ag: 7440-22-4	
				30%	EP	129915-35-1	
8	CMOS IC	Silicon	0.18	99%	Si	Si: 7440-21-3	
				1%	Al	Al: 7429-90-5	
9	Die attach	Gold bumps	0.018	100%	Au	Au: 7440-57-5	
Unit weight			12.4				

## 5.2. MATERIAL ANALYSIS & TEST RESULTS

Homogenous material information according to IPC-1752 standard

No.	Item Component Name	Sub Item Material Name	RoHS						Halogen				Phthalates				
			Pb	Cd	Hg	Cr+6	PBB	PBDE	F	Cl	Br	-	BBP	DBP	DEHP	DINP	
1	Resonator	Quartz Crystal	nd	nd	nd	nd	nd	nd	nd	nd	nd	nd	nd	nd	nd	nd	nd
2	Electrodes	Cr+Au	nd	nd	nd	nd	nd	nd	nd	nd	nd	nd	nd	nd	nd	nd	nd
3	Housing	Ceramic	nd	nd	nd	nd	nd	nd	nd	nd	nd	nd	nd	nd	nd	nd	nd
4	Lid	Ceramic Lid & Plating	nd	nd	nd	nd	nd	nd	nd	nd	nd	nd	nd	nd	nd	nd	nd
5	Seal	Solder Preform	nd	nd	nd	nd	nd	nd	nd	nd	nd	nd	nd	nd	nd	nd	nd
6	Terminations	Int. & ext. terminals	nd	nd	nd	nd	nd	nd	nd	nd	nd	nd	nd	nd	nd	nd	nd
7	Conductive adhesive	Silver filled Epoxy	nd	nd	nd	nd	nd	nd	nd	nd	nd	nd	nd	nd	nd	nd	nd
8	CMOS IC	Silicon & Die pad plating	nd	nd	nd	nd	nd	nd	nd	nd	nd	nd	nd	nd	nd	nd	nd
9	Die attach	Gold bumps	nd	nd	nd	nd	nd	nd	nd	nd	nd	nd	nd	nd	nd	nd	nd
	MDL	Measurement Detection Limit	2 ppm				5 ppm		50 ppm				0.003%		0.01%		

nd = not detectable

### Test methods:

**RoHS** Test method with reference to IEC 62321-5: 2013  
**Halogen** Test method with reference to BS EN 14582:2007  
**Phthalates** Test method with reference to EN 14372

MDL: 2 ppm (PBB / PBDE: 5 ppm)  
 MDL: 50 ppm  
 MDL: 0.003 % (DINP 0.01%)

**5.3. RECYCLING MATERIAL INFORMATION**

Recycling material information according to IPC-1752 standard.

Element weight is accumulated and referenced to the unit weight of 12.4 mg.

Item Material Name	No.	Item Component Name	Material Weight		Substance Element	CAS Number	Comment
			(mg)	(%)			
Quartz Crystal	1	Resonator	0.40	3.20	SiO <sub>2</sub>	14808-60-7	
Chromium	2	Electrodes	0.0004	0.003	Cr	Cr: 7440-47-3	
Ceramic	3	Housing	10.88	87.64	Al <sub>2</sub> O <sub>3</sub>	1344-28-1	
	4	Lid					
Gold	2	Electrodes	0.37	2.97	Au	Au: 7440-57-5	
	4	Lid					
	5	Seal					
	6	Terminations					
Tin	9	Die attach	0.076	0.61	Sn	Sn: 7440-31-5	
	5	Seal					
Nickel	4	Lid	0.096	0.77	Ni	Ni: 7440-02-0	
	6	Terminations					
Molybdenum	6	Terminations	0.26	2.13	Mo	Mo: 7439-98-7	
Silver	7a	Conductive adhesive	0.105	0.85	Ag	Ag: 7440-22-4	
Epoxy	7b	Conductive adhesive	0.045	0.36	EP	129915-35-1	
Silicon	8a	CMOS IC	0.18	1.46	Si	Si: 7440-21-3	
Aluminum	8b	CMOS IC	0.0018	0.015	Al	Al: 7429-90-5	
Unit weight (total)			12.4	100			

**5.4. ENVIRONMENTAL PROPERTIES & ABSOLUTE MAXIMUM RATINGS**

Package	Description
DFN-4 ceramic package	Dual Flat No Leads (DFN), hermetically sealed ceramic package with ceramic lid. Safe for Helium environment.

Parameter	Directive	Conditions	Value
Product weight (total)			12.4 mg
Storage temperature		Store as bare product	-55 to +125°C
Moisture sensitivity level (MSL)	IPC/JEDEC J-STD-020D		MSL1
FIT / MTBF			available on request

**Terminal finishes:**

Au flashed pads (T1 version):

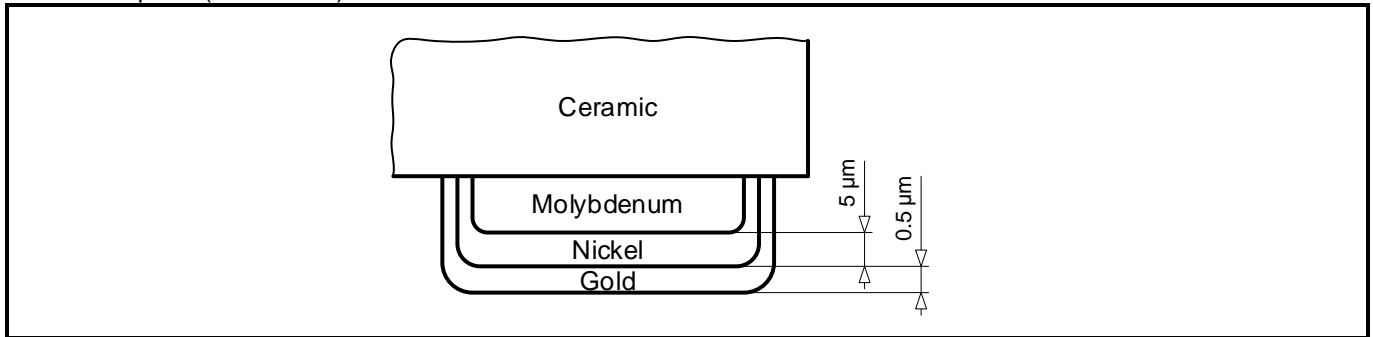

ENEPIG plated pads (T5 version):

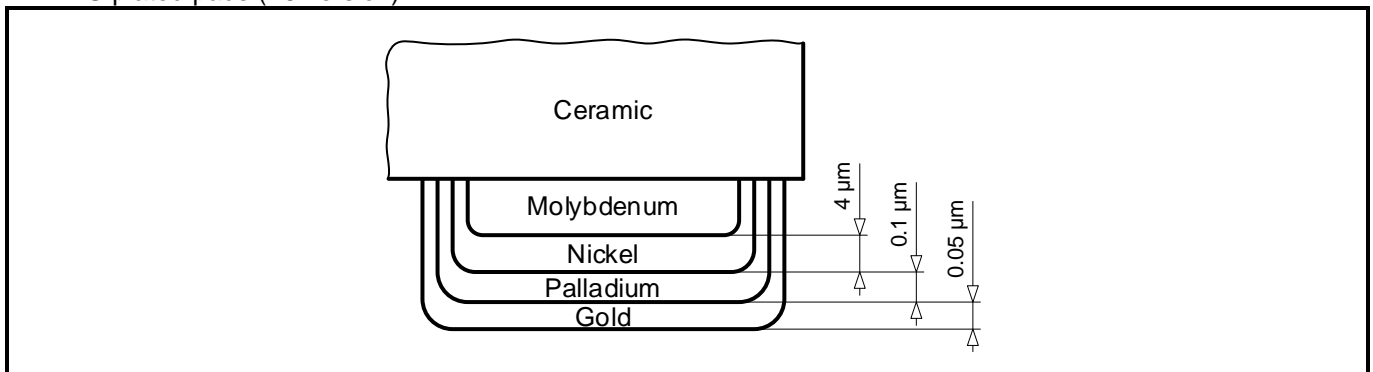

## 6. APPLICATION INFORMATION

### 6.1. OPERATING OV-0100-C7 MEDICAL

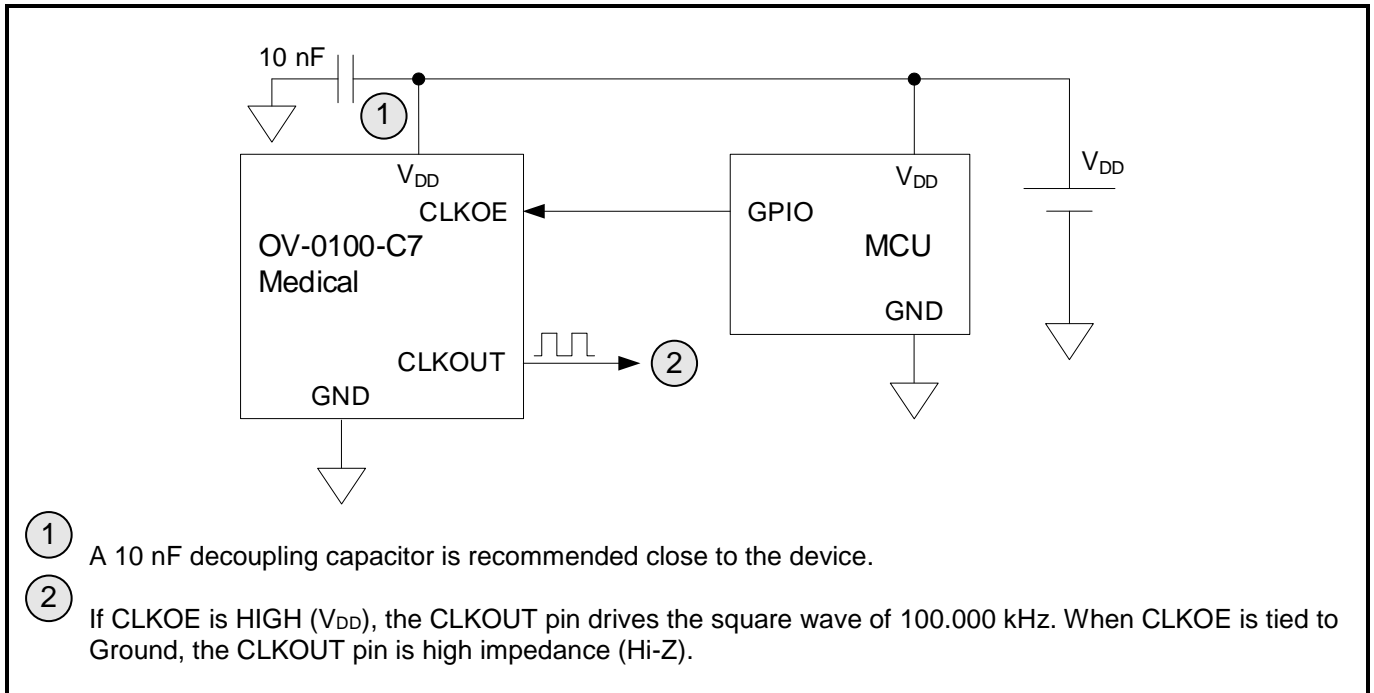



6.2. SOLDERING INFORMATION

Maximum Reflow Conditions in accordance with IPC/JEDEC J-STD-020C "Pb-free"

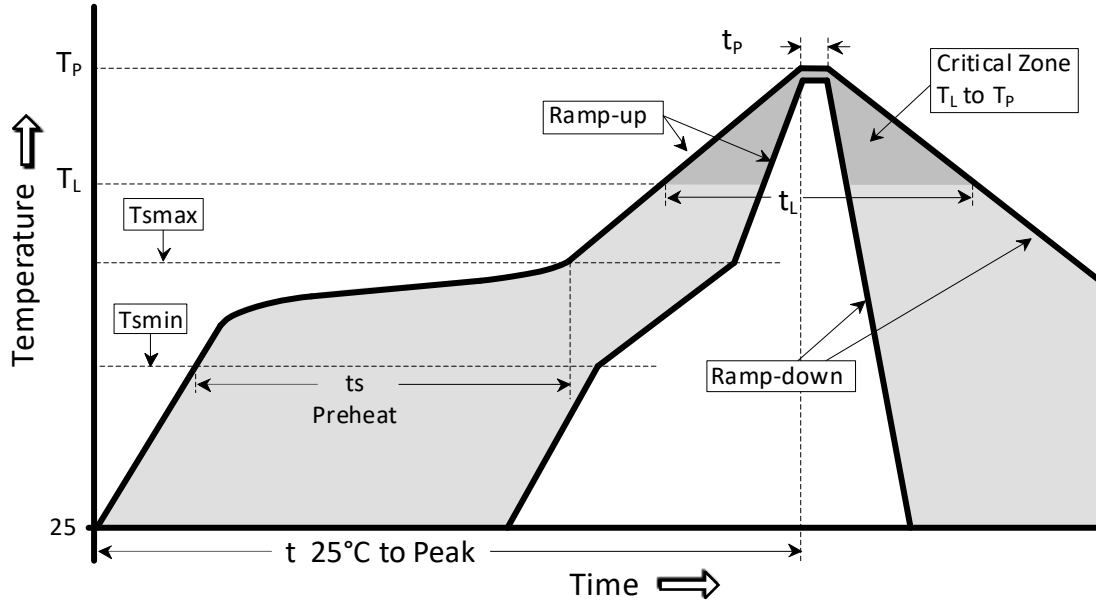

Temperature Profile	Symbol	Condition	Unit
Average ramp-up rate	( $T_{Smax}$ to $T_P$ )	3°C / second max	°C / s
Ramp down Rate	$T_{cool}$	6°C / second max	°C / s
Time 25°C to Peak Temperature	$T_{to-peak}$	8 minutes max	min
<b>Preheat</b>			
Temperature min	$T_{Smin}$	150	°C
Temperature max	$T_{Smax}$	200	°C
Time $T_{Smin}$ to $T_{Smax}$	$t_s$	60 – 180	sec
<b>Soldering above liquidus</b>			
Temperature liquidus	$T_L$	217	°C
Time above liquidus	$t_L$	60 – 150	sec
<b>Peak temperature</b>			
Peak Temperature	$T_p$	260	°C
Time within 5°C of peak temperature	$t_p$	20 – 40	sec

### 6.3. HANDLING PRECAUTIONS FOR MODULES WITH EMBEDDED CRYSTALS

The built-in tuning-fork crystal consists of pure Silicon Dioxide in crystalline form. The cavity inside the package is evacuated and hermetically sealed in order for the crystal blank to function undisturbed from air molecules, humidity and other influences.

#### Shock and vibration:

Keep the crystal / module from being exposed to **excessive mechanical shock and vibration**. Micro Crystal guarantees that the crystal / module will bear a mechanical shock of 5000 g / 0.3 ms.

The following special situations may generate either shock or vibration:

**Multiple PCB panels** - Usually at the end of the pick & place process the single PCBs are cut out with a router. These machines sometimes generate vibrations on the PCB that have a fundamental or harmonic frequency close to 100.000 kHz. This might cause breakage of crystal blanks due to resonance. Router speed should be adjusted to avoid resonant vibration.

**Ultrasonic cleaning** - Avoid cleaning processes using ultrasonic energy. These processes can damage crystals due to mechanical resonance of the crystal blank.

#### Overheating, rework high temperature exposure:

Avoid overheating the package. The package is sealed with a seal ring consisting of 80% Gold and 20% Tin. The eutectic melting temperature of this alloy is at 280°C. Heating the seal ring up to >280°C will cause melting of the metal seal which then, due to the vacuum, is sucked into the cavity forming an air duct. This happens when using hot-air-gun set at temperatures >300°C.

Use the following methods for rework:

- Use a hot-air- gun set at 270°C.
- Use 2 temperature controlled soldering irons, set at 270°C, with special-tips to contact all solder-joints from both sides of the package at the same time, remove part with tweezers when pad solder is liquid.

7. PACKING & SHIPPING INFORMATION

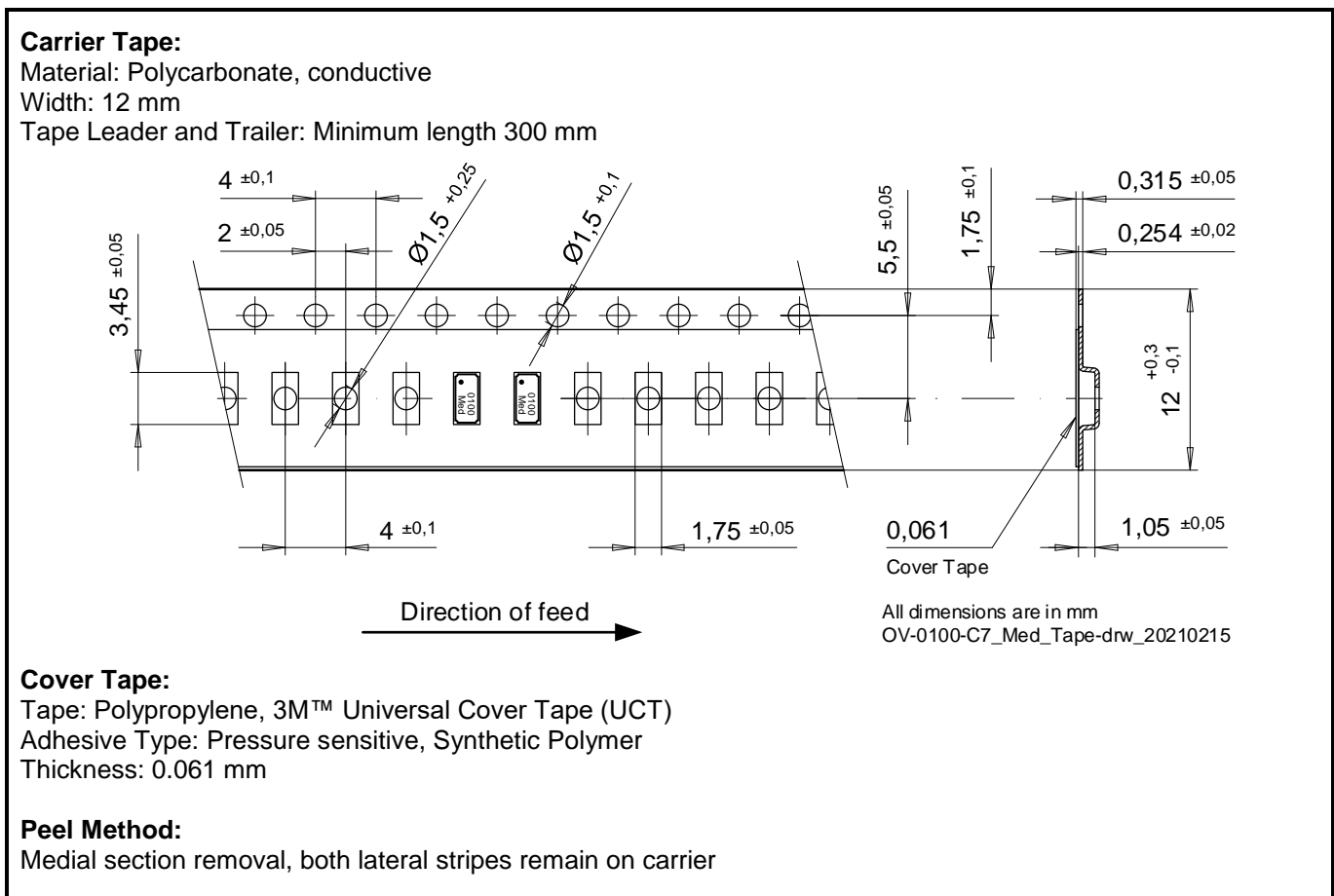
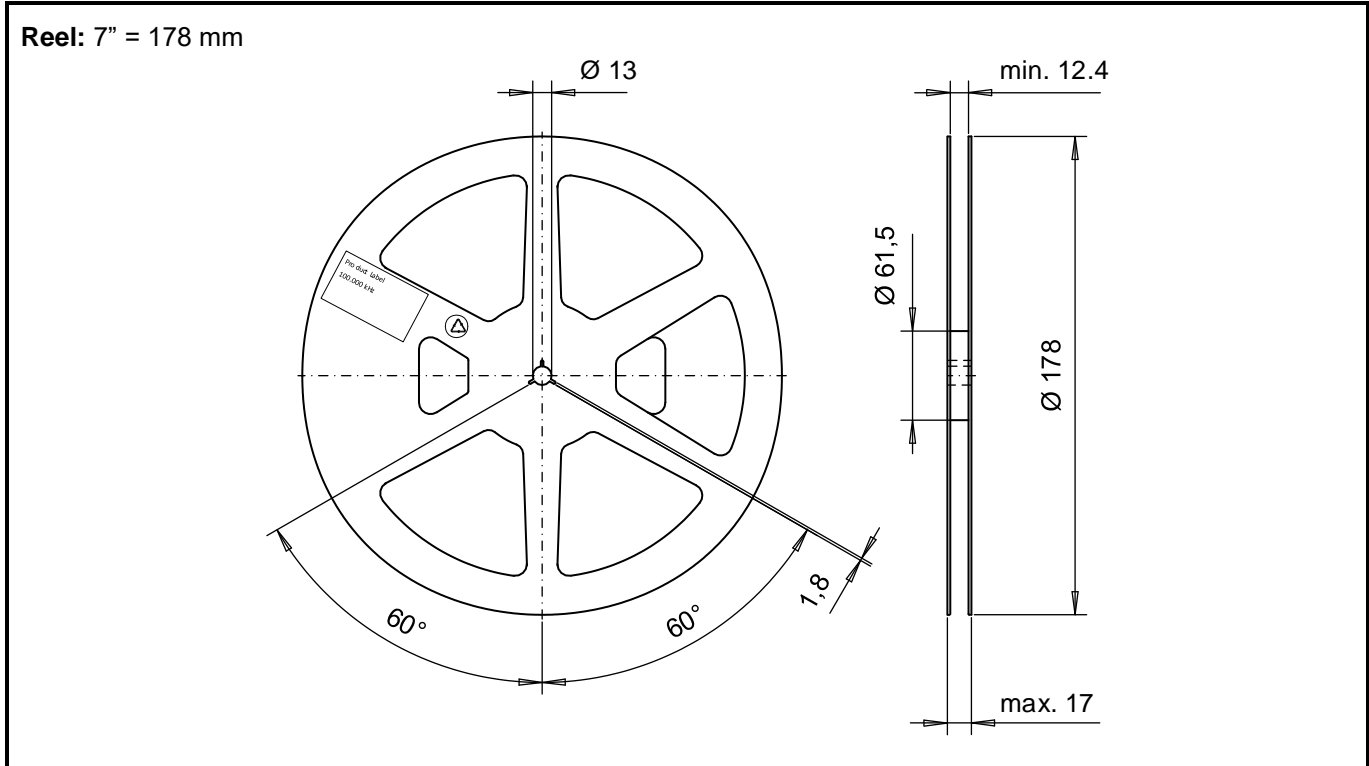

## 8. COMPLIANCE INFORMATION

Micro Crystal confirms that the product Low Power Clock Oscillator OV-0100-C7 Medical is compliant with “EU RoHS Directive” and “EU REACH Directives”.

Please find the actual Certificate of Conformance for Environmental Regulations on our website:

[CoC Environment OV\\_OM-Series.pdf](#)

## 9. DOCUMENT REVISION HISTORY

Date	Revision #	Revision Details
February 2021	1.0	First release

The information contained in this document is believed to be accurate and reliable. However, Micro Crystal assumes no responsibility for any consequences resulting from the use of such information nor for any infringement of patents or other rights of third parties, which may result from its use. In accordance with our policy of continuous development and improvement, Micro Crystal reserves the right to modify specifications mentioned in this publication without prior notice and as deemed necessary.

Any use of Products for the manufacture of arms is prohibited. Customer shall impose that same obligation upon all third-party purchasers.

Without the express written approval of Micro Crystal, Products are not authorized for use as components in safety and life supporting systems as well as in any implantable medical devices. The unauthorized use of Products in such systems / applications / equipment is solely at the risk of the customer and such customer agrees to defend and hold Micro Crystal harmless from and against any and all claims, suits, damages, cost, and expenses resulting from any unauthorized use of Products.

No licenses to patents or other intellectual property rights of Micro Crystal are granted in connection with the sale of Micro Crystal products, neither expressly nor implicitly. In respect of the intended use of Micro Crystal products by customer, customer is solely responsible for observing existing patents and other intellectual property rights of third parties and for obtaining, as the case may be, the necessary licenses.



A COMPANY OF THE  SWATCH GROUP

Micro Crystal AG  
Muehlestrasse 14  
CH-2540 Grenchen  
Switzerland

Phone +41 32 655 82 82  
sales@microcrystal.com  
www.microcrystal.com