

# **Application Manual**

## **OM-7605-C9**

### **Low Power Clock Oscillator 32.768 kHz**

**TABLE OF CONTENTS**

<b>1. OVERVIEW</b> .....	<b>3</b>
<b>1.1. GENERAL DESCRIPTION</b> .....	<b>3</b>
<b>1.2. APPLICATIONS</b> .....	<b>3</b>
<b>1.3. ORDERING INFORMATION</b> .....	<b>4</b>
<b>2. BLOCK DIAGRAM</b> .....	<b>5</b>
<b>2.1. PINOUT</b> .....	<b>5</b>
<b>2.2. PIN DESCRIPTION</b> .....	<b>5</b>
<b>2.3. DEVICE PROTECTION DIAGRAM</b> .....	<b>6</b>
<b>3. ELECTRICAL SPECIFICATIONS</b> .....	<b>7</b>
<b>3.1. ABSOLUTE MAXIMUM RATINGS</b> .....	<b>7</b>
<b>3.2. OPERATING PARAMETERS</b> .....	<b>7</b>
<b>3.3. TYPICAL CHARACTERISTICS</b> .....	<b>8</b>
<b>3.4. TIMING WAVEFORMS</b> .....	<b>8</b>
<b>3.5. OSCILLATOR PARAMETERS</b> .....	<b>9</b>
3.5.1. XTAL FREQUENCY VS. TEMPERATURE CHARACTERISTICS .....	<b>9</b>
<b>4. PACKAGE</b> .....	<b>10</b>
<b>4.1. DIMENSIONS AND SOLDER PAD LAYOUT</b> .....	<b>10</b>
4.1.1. RECOMMENDED THERMAL RELIEF .....	<b>10</b>
<b>4.2. MARKING AND PIN #1 INDEX</b> .....	<b>11</b>
<b>5. MATERIAL COMPOSITION DECLARATION &amp; ENVIRONMENTAL INFORMATION</b> .....	<b>12</b>
<b>5.1. HOMOGENOUS MATERIAL COMPOSITION DECLARATION</b> .....	<b>12</b>
<b>5.2. MATERIAL ANALYSIS &amp; TEST RESULTS</b> .....	<b>13</b>
<b>5.3. RECYCLING MATERIAL INFORMATION</b> .....	<b>14</b>
<b>5.4. ENVIRONMENTAL PROPERTIES &amp; ABSOLUTE MAXIMUM RATINGS</b> .....	<b>15</b>
<b>6. APPLICATION INFORMATION</b> .....	<b>16</b>
<b>6.1. OPERATING OM-7605-C9</b> .....	<b>16</b>
<b>6.2. SOLDERING INFORMATION</b> .....	<b>17</b>
<b>6.3. HANDLING PRECAUTIONS FOR MODULES WITH EMBEDDED CRYSTALS</b> .....	<b>18</b>
<b>7. PACKING &amp; SHIPPING INFORMATION</b> .....	<b>19</b>
<b>8. COMPLIANCE INFORMATION</b> .....	<b>20</b>
<b>9. DOCUMENT REVISION HISTORY</b> .....	<b>20</b>

## OM-7605-C9

### Low Power Clock Oscillator 32.768 kHz

#### 1. OVERVIEW

- Oscillator with built-in “Tuning Fork” crystal oscillating at 32.768 kHz
- Very tight frequency tolerance:  $\pm 20$  ppm
- Excellent oscillator stability:  $< 3$  ppm/V
- High shock and vibration resistance
- Wide operating voltage range: 1.6 V to 5.5 V
- Very low power consumption: typ. 450 nA
- Standard operating temperature range  $T_A$ :  $-40$  to  $+85^\circ\text{C}$
- Extended operating temperature range  $T_B$ :  $-40$  to  $+125^\circ\text{C}$
- CLKOUT enable/disable
- Low aging rate
- Ultra-miniature ceramic SMT package with metal lid, RoHS-compliant and 100% lead-free: 1.6 x 1.0 x 0.6 mm
- Automotive qualification according to AEC-Q200 available

#### 1.1. GENERAL DESCRIPTION

The OM-7605-C9 combines an advanced very low power CMOS oscillator circuitry together with a 32.768 kHz “tuning-fork” crystal in an ultra-miniature ceramic package with metal lid. No external components are required. The very low power consumption over a wide supply voltage and temperature range is the key feature of this product. The frequency output on CLKOUT pin can be enabled/disabled by the CLKOE pin. The CLKOUT frequency is enabled when CLKOE pin is connected to  $V_{DD}$ . When the CLKOE pin is tied to GND the frequency is disabled and the CLKOUT pin is high impedance (Hi-Z).

The OM-7605-C9 is also available in extended temperature range version ( $-40^\circ\text{C}$  to  $+125^\circ\text{C}$ ).

#### 1.2. APPLICATIONS

The OM-7605-C9 oscillator module combines very low power consumption with a ultra-small ceramic package:

- Smallest oscillator module (embedded XTAL) in a ultra-small 1.6 x 1.0 x 0.6 mm lead-free ceramic package
- Price competitive

The unique size and the competitive pricing make this product perfectly suitable for many applications:

- Communication: IoT / Wearables / Wireless Sensors and Tags / Handsets
- Automotive: M2M / Navigation & Tracking Systems / Dashboard / Tachometers / Engine Controller  
Car Audio & Entertainment Systems
- Metering: E-Meter / Heating Counter / Smart Meters / PV Converter / Utility metering
- Outdoor: ATM & POS systems / Surveillance & Safety systems / Ticketing Systems
- Medical: Glucose Meter / Health Monitoring Systems
- Safety: Security & Camera Systems / Door Lock & Access Control
- Consumer: Gambling Machines / TV & Set Top Boxes / White Goods
- Automation: PLC / Data Logger / Home & Factory Automation / Industrial and Consumer Electronics

**1.3. ORDERING INFORMATION**

Example: OM-7605-C9 -20/+20ppm TA QC

Code	Operating temperature range
TA (Standard)	-40 to +85°C
TB	-40 to +125°C

Code	Qualification
QC (Standard)	Commercial Grade
QA	Automotive Grade AEC-Q200

## 2. BLOCK DIAGRAM

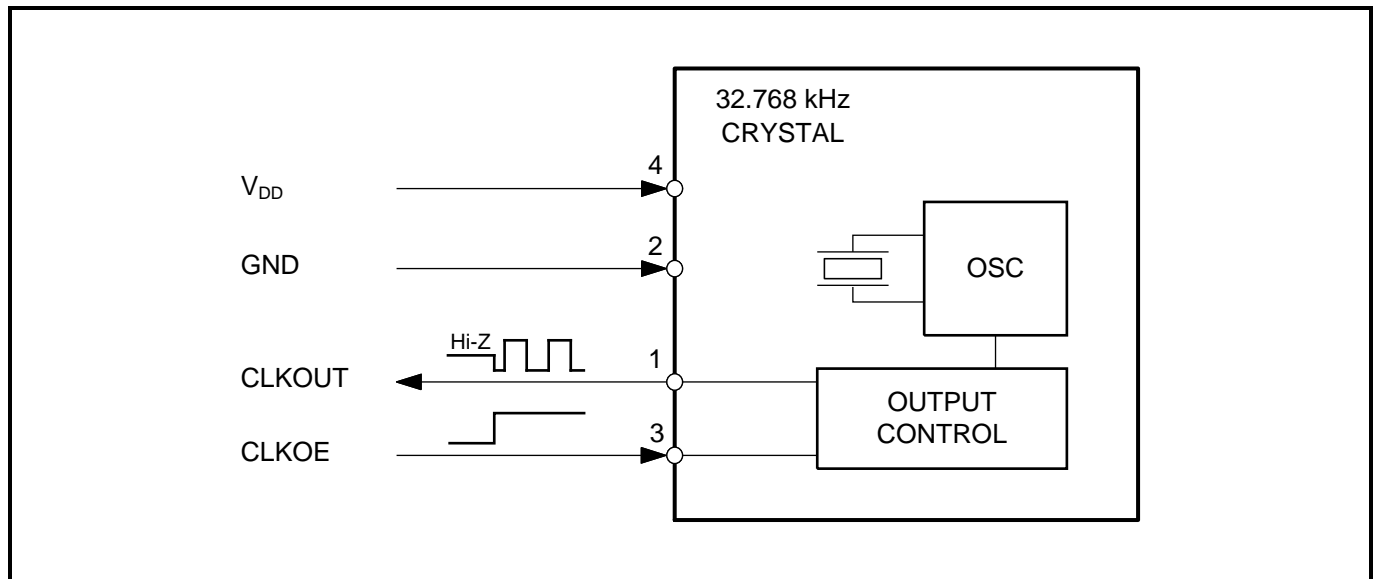

### 2.1. PINOUT

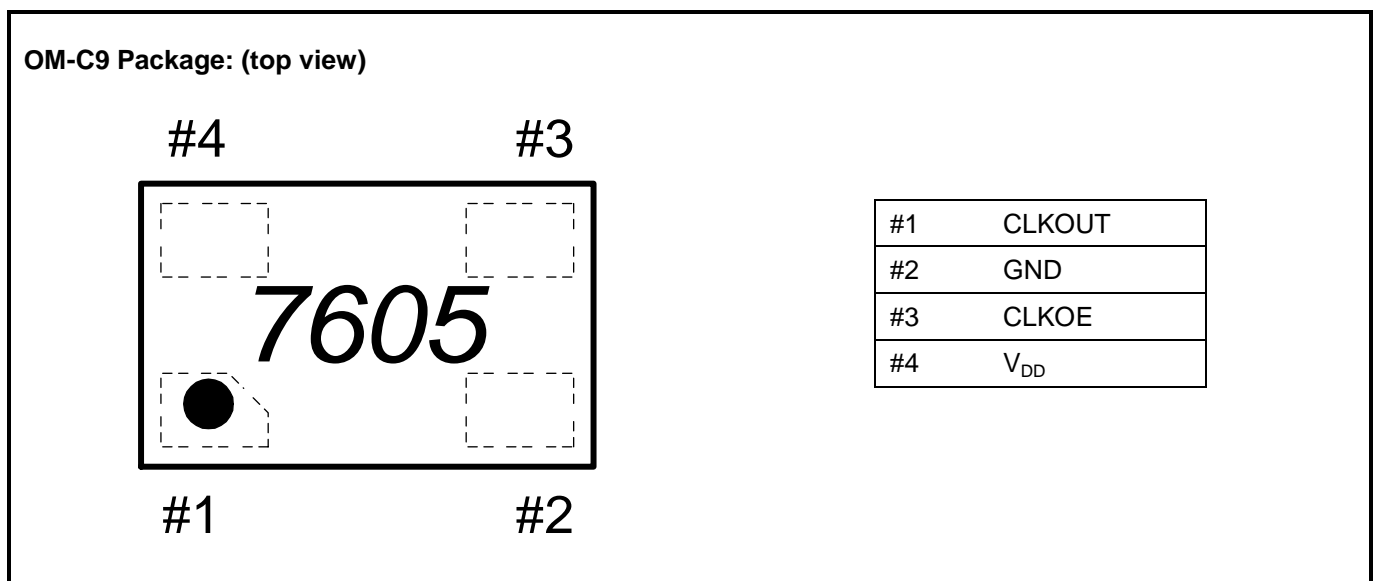

### 2.2. PIN DESCRIPTION

Symbol	Pin #	Description
CLKOUT	1	Clock Output; push-pull; controlled by CLKOE. If CLKOE is HIGH (V <sub>DD</sub> ), the CLKOUT pin drives the square wave of 32.768 kHz. When CLKOE is tied to Ground, the CLKOUT pin is high impedance (Hi-Z).
GND	2	Ground.
CLKOE	3	Input to enable the CLKOUT pin. If CLKOE is HIGH, the CLKOUT pin is in output mode. When CLKOE is tied to Ground, the CLKOUT pin is high impedance (Hi-Z).
V <sub>DD</sub>	4	Power Supply Voltage.

### 2.3. DEVICE PROTECTION DIAGRAM

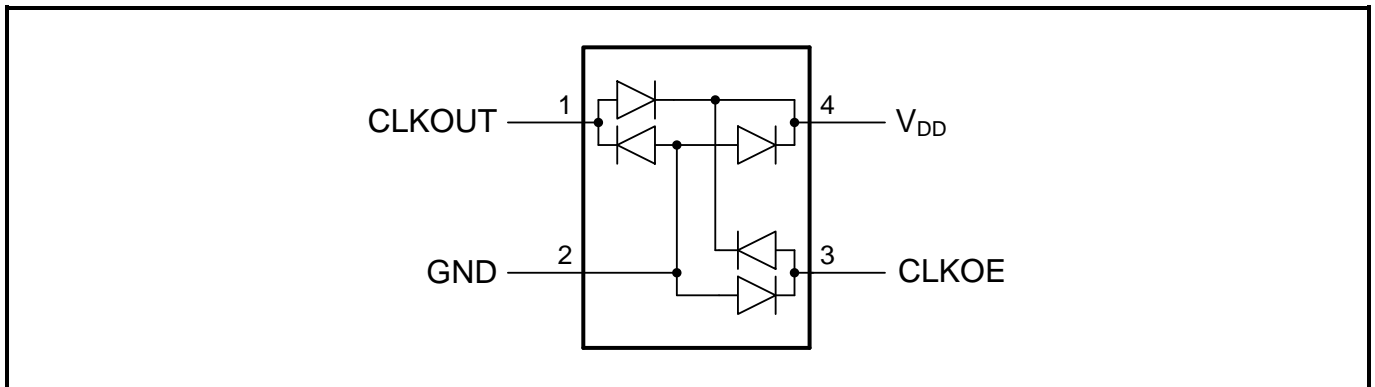

### 3. ELECTRICAL SPECIFICATIONS

#### 3.1. ABSOLUTE MAXIMUM RATINGS

Absolute Maximum Ratings according to IEC 60134:

SYMBOL	PARAMETER	CONDITIONS	MIN	MAX	UNIT
V <sub>DD</sub>	Power supply voltage		-0.5	6.0	V
V <sub>I</sub>	Input voltage		-0.5	6.0	V
V <sub>O</sub>	Output voltage		-0.5	6.0	V
T <sub>OPRA</sub>	Standard operating temperature T <sub>A</sub>		-40	85	°C
T <sub>OPRB</sub>	Extended operating temperature T <sub>B</sub>		-40	125	°C
T <sub>STO</sub>	Storage temperature	Stored as bare product	-55	125	°C
T <sub>PEAK</sub>	Maximum reflow condition	JEDEC J-STD-020C		265	°C

#### 3.2. OPERATING PARAMETERS

For this Table, V<sub>DD</sub> = 3.0 V; GND = 0 V; T<sub>A</sub> = 25 °C; unless otherwise indicated.

Operating Parameters:

SYMBOL	PARAMETER	CONDITIONS	MIN	TYP	MAX	UNIT
<b>Supply</b>						
V <sub>DD</sub>	Power supply voltage	T <sub>A</sub> : -40 to +85°C	1.6		5.5	V
		T <sub>B</sub> : -40 to +125°C	2.25		5.5	
V <sub>DDSR</sub>	V <sub>DD</sub> slew rate				±0.5	V/ms
I <sub>DD</sub>	V <sub>DD</sub> Supply Current. CLKOUT disabled. (1)	V <sub>DD</sub> = 3.0 V, T <sub>A</sub> = 25°C		450	650	nA
		V <sub>DD</sub> = 5.0 V, T <sub>A</sub> = 25°C		680	900	
		V <sub>DD</sub> = 3.0 V, T <sub>A</sub> = -40 to 85°C			1300	
		V <sub>DD</sub> = 5.0 V, T <sub>A</sub> = -40 to 85°C			1800	
		V <sub>DD</sub> = 3.0 V, T <sub>A</sub> = -40 to 125°C			1950	
		V <sub>DD</sub> = 5.0 V, T <sub>A</sub> = -40 to 125°C			2700	
<b>Input CLKOE</b>						
V <sub>I</sub>	Input voltage		GND -0.5		V <sub>DD</sub> +0.5	V
V <sub>IL</sub>	LOW level input voltage		GND		0.3 V <sub>DD</sub>	V
V <sub>IH</sub>	HIGH level input voltage		0.7 V <sub>DD</sub>		V <sub>DD</sub>	V
<b>Output CLKOUT</b>						
V <sub>OH</sub>	HIGH level output voltage	I <sub>OH</sub> = -400 µA, V <sub>DD</sub> = 1.6 to 5.5 V	V <sub>DD</sub> - 0.4			V
V <sub>OL</sub>	LOW level output voltage	I <sub>OL</sub> = 400 µA, V <sub>DD</sub> = 1.6 to 5.5 V			GND +0.4	V
I <sub>OZ</sub>	Hi-Z leakage current	CLKOE = GND, CLKOUT = V <sub>DD</sub> or GND			±100	nA
C <sub>L</sub>	Output load capacitance	CMOS			15	pF
t <sub>r</sub>	Output rise time	C <sub>L</sub> = 10 pF, 10% to 90% V <sub>DD</sub>		30	70	ns
t <sub>f</sub>	Output fall time	C <sub>L</sub> = 10 pF, 10% to 90% V <sub>DD</sub>		30	70	ns
t <sub>CKH</sub>	CLKOUT enable time (see following diagram)		0		0.5	µs
t <sub>CKL</sub>	CLKOUT disable time (see following diagram)				0	µs
(1) When CLKOUT is enabled (CLKOE is HIGH) the additional V <sub>DD</sub> supply current ΔI <sub>DD</sub> can be calculated as follows: ΔI <sub>DD</sub> = C <sub>L</sub> × V <sub>DD</sub> × f <sub>OUT</sub> e.g. ΔI <sub>DD</sub> = 10 pF × 3.0 V × 32768 Hz = 980 nA						

### 3.3. TYPICAL CHARACTERISTICS

Supply current  $I_{DD}$  vs. Supply voltage  $V_{DD}$ :  $T_A = 25^\circ\text{C}$ , CLKOUT disabled

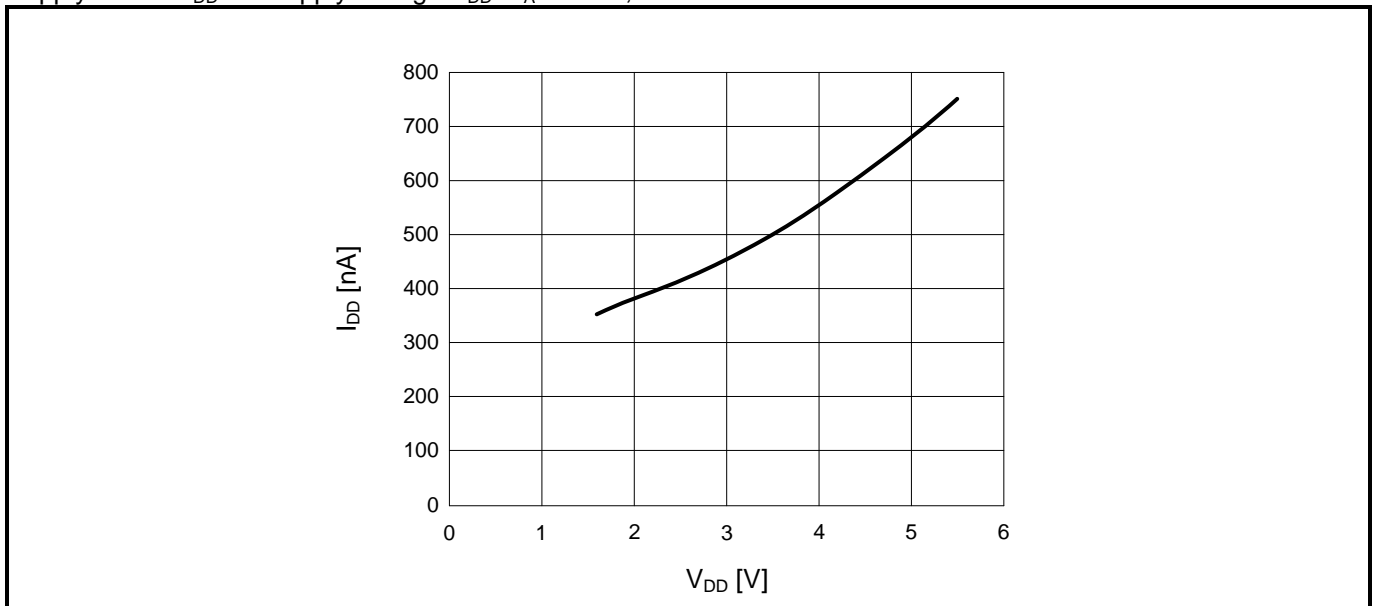

### 3.4. TIMING WAVEFORMS

CLKOUT enable/disable time:

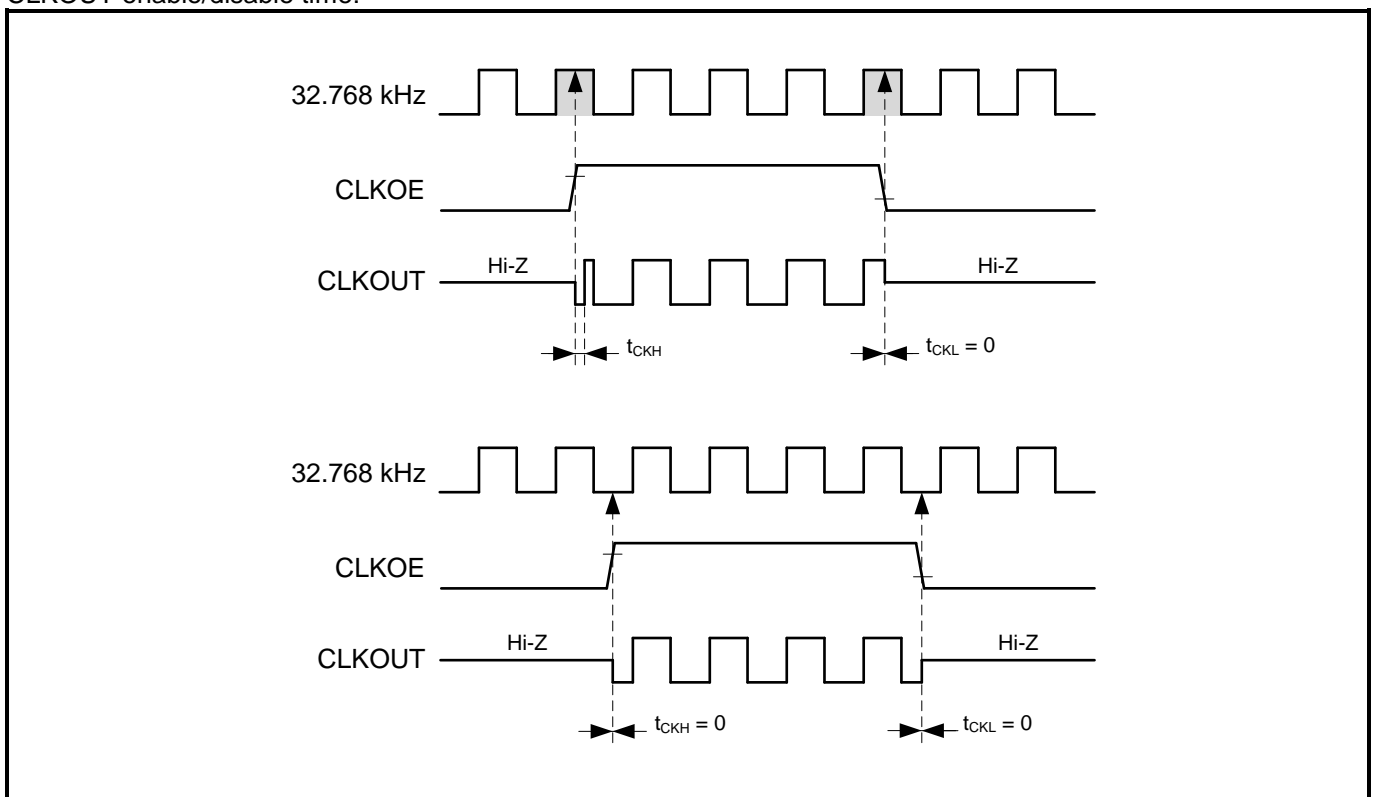



### 3.5. OSCILLATOR PARAMETERS

For this Table,  $V_{DD} = 3.0\text{ V}$ ;  $GND = 0\text{ V}$ ;  $T_A = 25\text{ }^\circ\text{C}$ ; unless otherwise indicated.

Oscillator Parameters:

SYMBOL	PARAMETER	CONDITIONS	MIN	TYP	MAX	UNIT
<b>Xtal General</b>						
f	Crystal Frequency			32.768		kHz
t <sub>START</sub>	Oscillator start-up time			50	500	ms
$\bar{D}_{CLKOUT}$	CLKOUT duty cycle	T <sub>A</sub> : -40 to +85°C V <sub>DD</sub> = 1.6 to 5.5 V T <sub>B</sub> : -40 to +125°C V <sub>DD</sub> = 2.25 to 5.5 V	40		60	%
<b>Xtal Frequency Characteristics</b>						
$\Delta f/f$	Frequency accuracy			±10	±20	ppm
$\Delta f/V$	Frequency vs. voltage characteristics	1.6 V ≤ V <sub>DD</sub> ≤ 5.5 V			±3	ppm/V
$\Delta f/f_{TOPR}$	Frequency vs. temperature characteristics	T <sub>OPR</sub> = -40°C to +125°C V <sub>DD</sub> = 3.0 V		-0.035 <sup>ppm</sup> /°C <sup>2</sup> (T <sub>OPR</sub> -T <sub>0</sub> ) <sup>2</sup> ±10%		ppm
T <sub>0</sub>	Turnover temperature		20		30	°C
$\Delta f/f$	Aging first year max.				±3	ppm

#### 3.5.1. XTAL FREQUENCY VS. TEMPERATURE CHARACTERISTICS

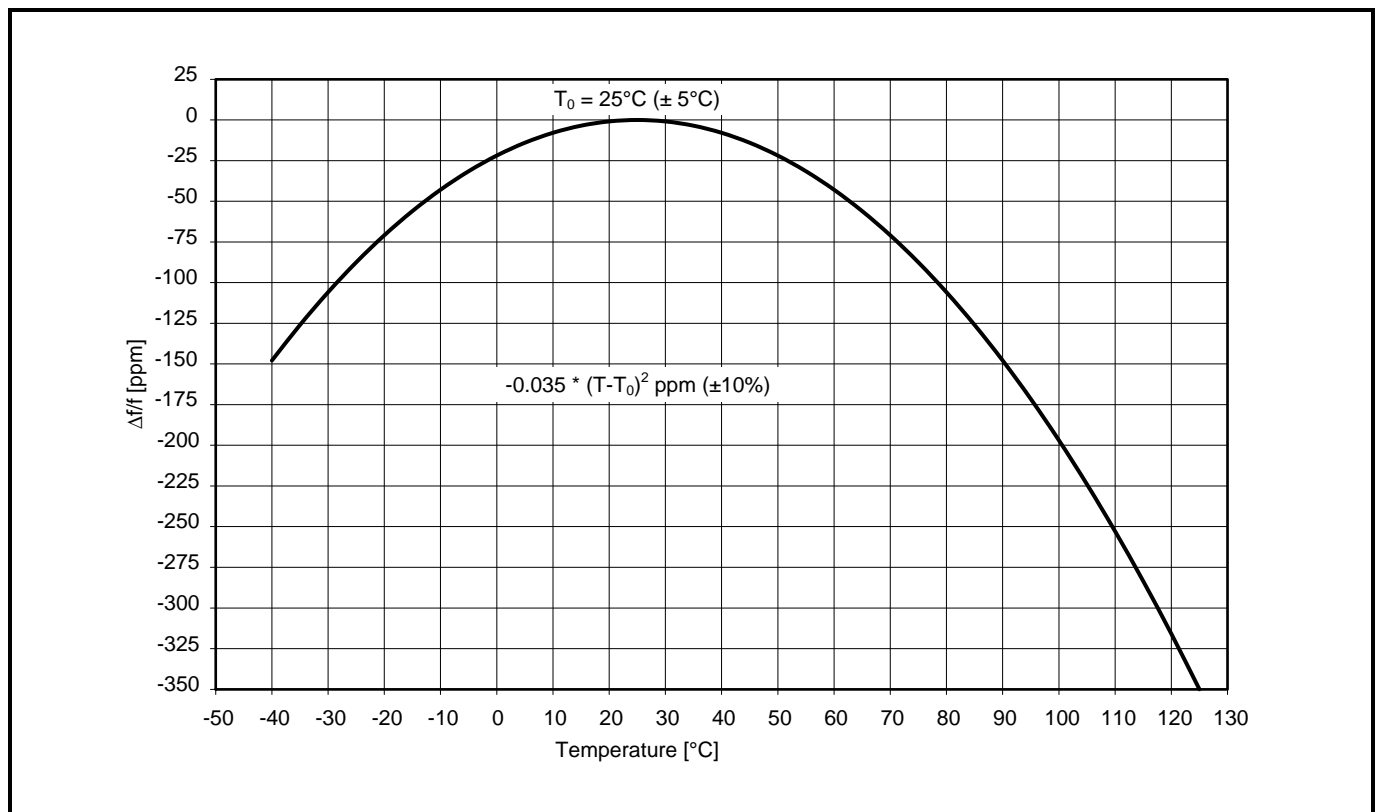

## 4. PACKAGE

### 4.1. DIMENSIONS AND SOLDER PAD LAYOUT

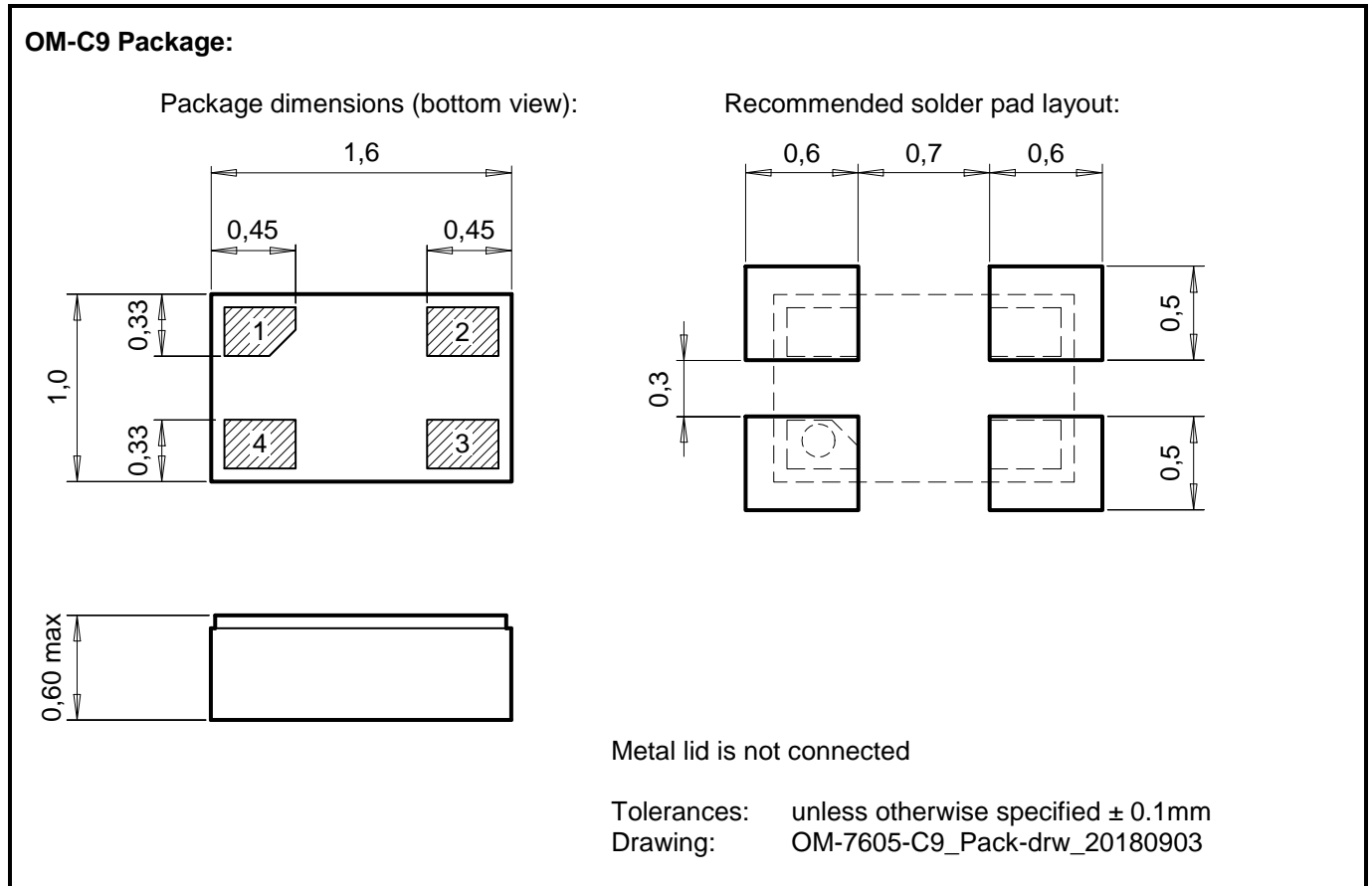

All dimensions in mm typical.

#### 4.1.1. RECOMMENDED THERMAL RELIEF

When connecting a pad to a copper plane, thermal relief is recommended.

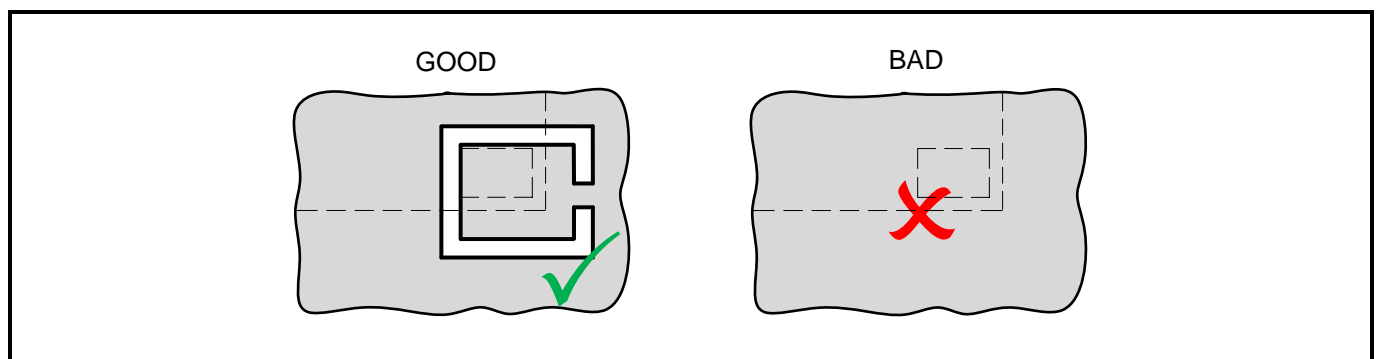

#### 4.2. MARKING AND PIN #1 INDEX

Laser marking OM-7605-C9 Package: (top view)

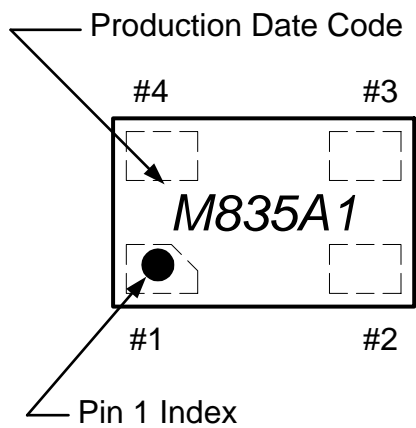

## 5. MATERIAL COMPOSITION DECLARATION & ENVIRONMENTAL INFORMATION

### 5.1. HOMOGENOUS MATERIAL COMPOSITION DECLARATION

Homogenous material information according to IPC-1752 standard

**Material Composition OM-7605-C9:**

(Symbolic drawing)

No.	Item Component Name	Sub Item Material Name	Material Weight		Substance Element	CAS Number	Comment
			(mg)	(%)			
1	Resonator	Quartz Crystal	0.099	100%	SiO <sub>2</sub>	14808-60-7	
2	Electrodes	Cr+Au	0.0035	3%	Cr	Cr: 7440-47-3	
				97%	Au	Au: 7440-57-5	
3	Housing	Ceramic	1.47	100%	Al <sub>2</sub> O <sub>3</sub>	1344-28-1	
4	Metal Lid	Kovar Lid	0.81	90%	Fe53Ni29Co18	Fe: 7439-89-6 Ni: 7440-02-0 Co: 7440-48-4	Metal Lid (Kovar)
				9%	Ni	Ni: 7440-02-0	Nickel plating
				1%	Au	Au: 7440-57-5	Gold plating
5	Seal	Solder Preform	0.15	80% 20%	Au80 / Sn20	Au: 7440-57-5 Sn: 7440-31-5	Premelted on Metal Lid
6	Terminations	Internal and external terminals	0.41	80%	Mo	Mo: 7439-98-7	Molybdenum
				15%	Ni	Ni: 7440-02-0	Nickel plating
				5%	Au, 0.5 micron	Au: 7440-57-5	Gold plating
7	Resonator attach	Gold bumps	0.012	100%	Au	7440-57-5	
8	CMOS IC	Silicon	0.088	98%	Si	Si: 7440-21-3	
		Die pad plating		2%	Al	Al: 7429-90-5	
9	Die attach	Gold bumps	0.018	100%	Au	Au: 7440-57-5	
Unit weight			3.06				

## 5.2. MATERIAL ANALYSIS & TEST RESULTS

Homogenous material information according to IPC-1752 standard

No.	Item Component Name	Sub Item Material Name	RoHS						Halogen				Phthalates			
			Pb	Cd	Hg	Cr+6	PBB	PBDE	F	Cl	Br	I	BBP	DBP	DEHP	DINP
1	Resonator	Quartz Crystal	nd	nd	nd	nd	nd	nd	nd	nd	nd	nd	nd	nd	nd	nd
2	Electrodes	Cr+Au	nd	nd	nd	nd	nd	nd	nd	nd	nd	nd	nd	nd	nd	nd
3	Housing	Ceramic	nd	nd	nd	nd	nd	nd	nd	nd	nd	nd	nd	nd	nd	nd
4	Metal Lid	Kovar Lid & Plating	nd	nd	nd	nd	nd	nd	nd	nd	nd	nd	nd	nd	nd	nd
5	Seal	Solder Preform	nd	nd	nd	nd	nd	nd	nd	nd	nd	nd	nd	nd	nd	nd
6	Terminations	Int. & ext. terminals	nd	nd	nd	nd	nd	nd	nd	nd	nd	nd	nd	nd	nd	nd
7	Resonator attach	Gold bumps	nd	nd	nd	nd	nd	nd	nd	nd	nd	nd	nd	nd	nd	nd
8	CMOS IC	Silicon & Die pad plating	nd	nd	nd	nd	nd	nd	nd	nd	nd	nd	nd	nd	nd	nd
9	Die attach	Gold bumps	nd	nd	nd	nd	nd	nd	nd	nd	nd	nd	nd	nd	nd	nd
	MDL	Measurement Detection Limit	2 ppm				5 ppm		50 ppm				0.003%		0.01%	

nd = not detectable

### Test methods:

**RoHS** Test method with reference to IEC 62321-5: 2013  
**Halogen** Test method with reference to BS EN 14582:2007  
**Phthalates** Test method with reference to EN 14372

MDL: 2 ppm (PBB / PBDE: 5 ppm)  
 MDL: 50 ppm  
 MDL: 0.003 % (DINP 0.01%)

**5.3. RECYCLING MATERIAL INFORMATION**

Recycling material information according to IPC-1752 standard.

Element weight is accumulated and referenced to the unit weight of 3.06 mg.

Item Material Name	No.	Item Component Name	Material Weight		Substance Element	CAS Number	Comment
			(mg)	(%)			
Quartz Crystal	1	Resonator	0.099	3.23	SiO <sub>2</sub>	14808-60-7	
Chromium	2	Electrodes	0.0001	0.003	Cr	Cr: 7440-47-3	
Ceramic	3	Housing	1.47	48.03	Al <sub>2</sub> O <sub>3</sub>	1344-28-1	
Gold	2 4 5 6 7 9	Electrodes Metal Lid Seal Terminations Resonator attach Die attach	0.18	5.95	Au	Au: 7440-57-5	
Tin	5	Seal	0.03	0.98	Sn	Sn: 7440-31-5	
Nickel	4 6	Metal Lid Terminations	0.134	4.39	Ni	Ni: 7440-02-0	
Molybdenum	6	Terminations	0.33	10.72	Mo	Mo: 7439-98-7	
Kovar	4	Metal Lid	0.73	23.82	Fe <sub>53</sub> Ni <sub>29</sub> Co <sub>18</sub>	Fe: 7439-89-6 Ni: 7440-02-0 Co: 7440-48-4	
Silicon	8a	CMOS IC	0.086	2.82	Si	Si: 7440-21-3	
Aluminum	8b	CMOS IC	0.0018	0.058	Al	Al: 7429-90-5	
Unit weight (total)			3.06	100			

**5.4. ENVIRONMENTAL PROPERTIES & ABSOLUTE MAXIMUM RATINGS**

Package	Description
SON-4	Small Outline Non-leaded (SON), ceramic package with metal lid

Parameter	Directive	Conditions	Value
Product weight (total)			3.06 mg
Storage temperature		Store as bare product	-55 to +125°C
Moisture sensitivity level (MSL)	IPC/JEDEC J-STD-020D		MSL1
FIT / MTBF			available on request

Terminal finish:

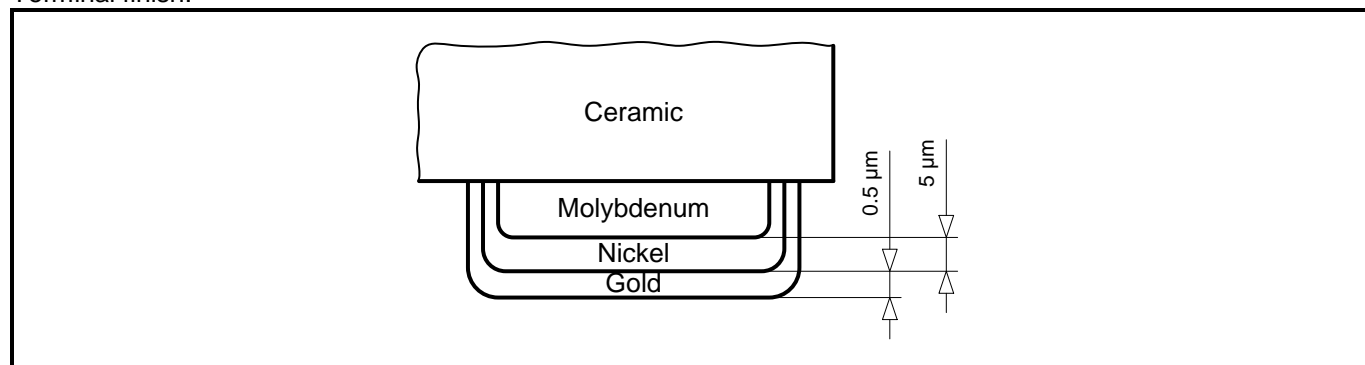

## 6. APPLICATION INFORMATION

### 6.1. OPERATING OM-7605-C9

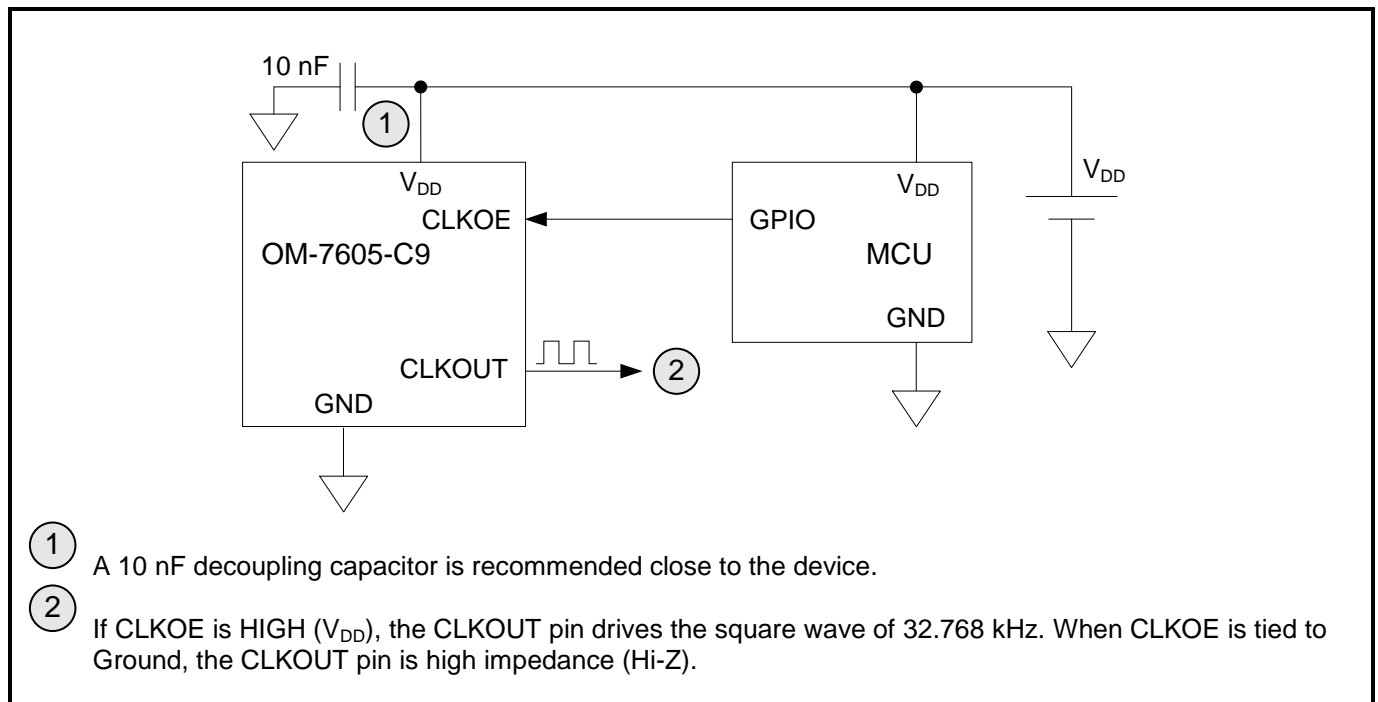



6.2. SOLDERING INFORMATION

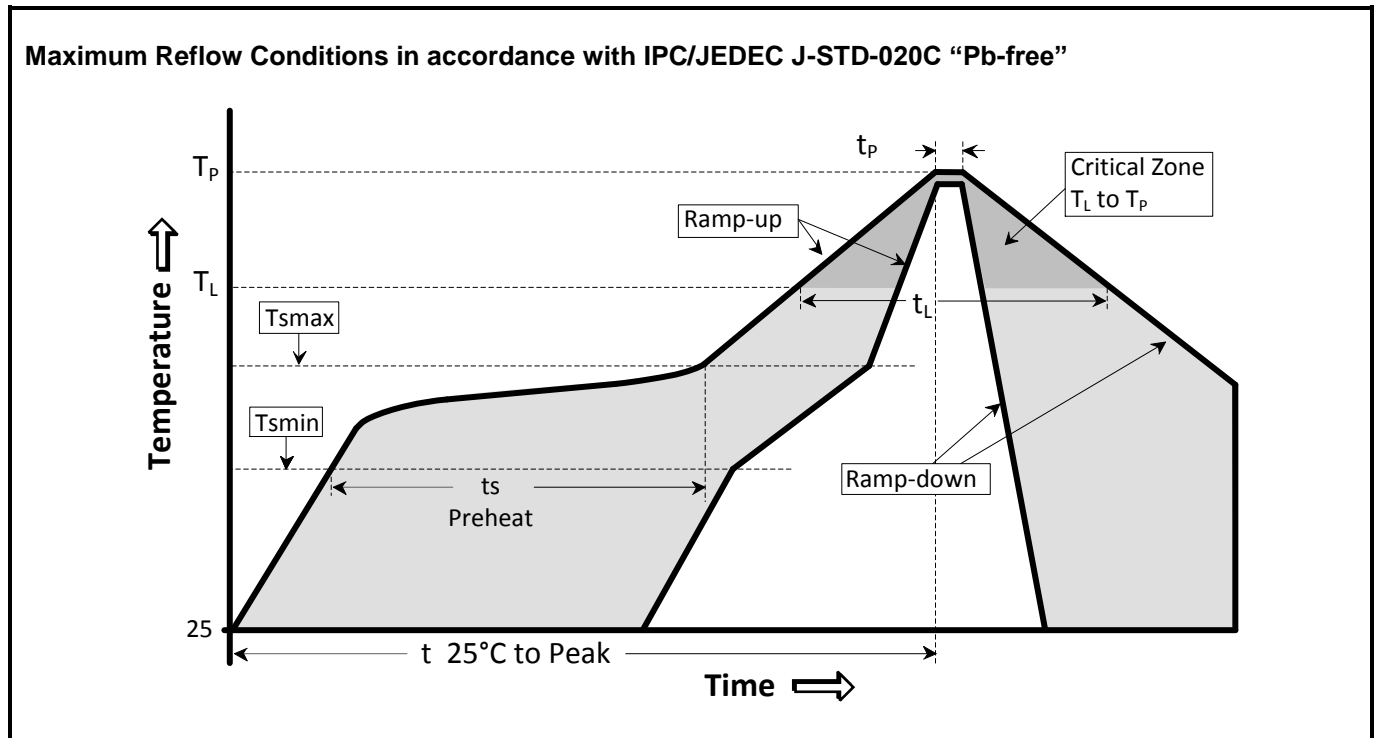

Temperature Profile	Symbol	Condition	Unit
Average ramp-up rate	( $T_{s_{max}}$ to $T_p$ )	3°C / second max	°C / s
Ramp down Rate	$T_{cool}$	6°C / second max	°C / s
Time 25°C to Peak Temperature	$T_{to-peak}$	8 minutes max	min
<b>Preheat</b>			
Temperature min	$T_{s_{min}}$	150	°C
Temperature max	$T_{s_{max}}$	200	°C
Time $T_{s_{min}}$ to $T_{s_{max}}$	$t_s$	60 – 180	sec
<b>Soldering above liquidus</b>			
Temperature liquidus	$T_L$	217	°C
Time above liquidus	$t_L$	60 – 150	sec
<b>Peak temperature</b>			
Peak Temperature	$T_p$	260	°C
Time within 5°C of peak temperature	$t_p$	20 – 40	sec

### 6.3. HANDLING PRECAUTIONS FOR MODULES WITH EMBEDDED CRYSTALS

The built-in tuning-fork crystal consists of pure Silicon Dioxide in crystalline form. The cavity inside the package is evacuated and hermetically sealed in order for the crystal blank to function undisturbed from air molecules, humidity and other influences.

#### Shock and vibration:

Keep the crystal / module from being exposed to **excessive mechanical shock and vibration**. Micro Crystal guarantees that the crystal / module will bear a mechanical shock of 5000 g / 0.3 ms.

The following special situations may generate either shock or vibration:

**Multiple PCB panels** - Usually at the end of the pick & place process the single PCBs are cut out with a router. These machines sometimes generate vibrations on the PCB that have a fundamental or harmonic frequency close to 32.768 kHz. This might cause breakage of crystal blanks due to resonance. Router speed should be adjusted to avoid resonant vibration.

**Ultrasonic cleaning** - Avoid cleaning processes using ultrasonic energy. These processes can damage crystals due to mechanical resonance of the crystal blank.

#### Overheating, rework high temperature exposure:

Avoid overheating the package. The package is sealed with a seal ring consisting of 80% Gold and 20% Tin. The eutectic melting temperature of this alloy is at 280°C. Heating the seal ring up to >280°C will cause melting of the metal seal which then, due to the vacuum, is sucked into the cavity forming an air duct. This happens when using hot-air-gun set at temperatures >300°C.

Use the following methods for rework:

- Use a hot-air- gun set at 270°C.
- Use 2 temperature controlled soldering irons, set at 270°C, with special-tips to contact all solder-joints from both sides of the package at the same time, remove part with tweezers when pad solder is liquid.

7. PACKING & SHIPPING INFORMATION

Reel: 7" = 178 mm

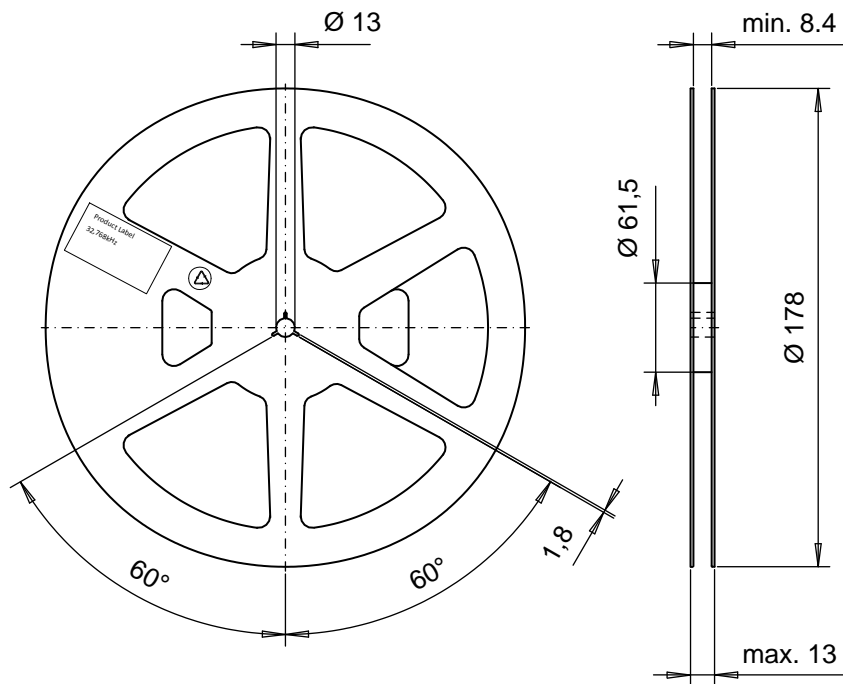

**Carrier Tape:**

Material: Polycarbonate

Width: 8 mm

Tape Leader and Trailer: Minimum length 300 mm

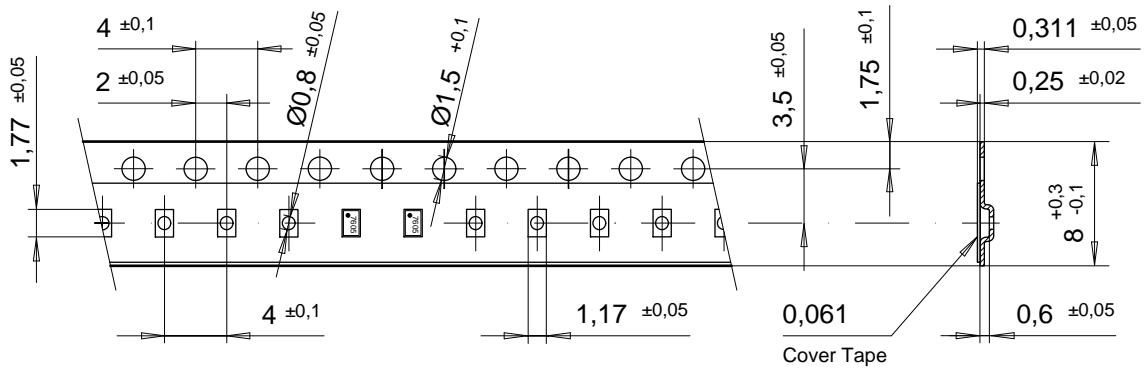

All dimensions are in mm  
OM-7605-C9\_Tape-drw\_20180905

**Cover Tape:**

Tape: Polypropylene, 3M™ Universal Cover Tape (UCT)

Adhesive Type: Pressure sensitive, Synthetic Polymer

Thickness: 0.061 mm

**Peel Method:**

Medial section removal, both lateral stripes remain on carrier

## 8. COMPLIANCE INFORMATION

Micro Crystal confirms that the standard product Low Power Clock Oscillator OM-7605-C9 is compliant with “EU RoHS Directive” and “EU REACH Directives”.

Please find the actual Certificate of Conformance for Environmental Regulations on our website:

[CoC\\_Environment\\_OV&OM-Series.pdf](#)

## 9. DOCUMENT REVISION HISTORY

Date	Revision #	Revision Details
September 2018	1.0	First release

Information furnished is believed to be accurate and reliable. However, Micro Crystal assumes no responsibility for the consequences of use of such information nor for any infringement of patents or other rights of third parties which may result from its use. In accordance with our policy of continuous development and improvement, Micro Crystal reserves the right to modify specifications mentioned in this publication without prior notice. This product is not authorized for use as critical component in life support devices or systems.



A COMPANY OF THE  SWATCH GROUP