

Application Manual

OCXOS

**Standard OCXO
with Sine Wave Output
– up to 54 MHz**

TABLE OF CONTENTS

1. OVERVIEW	3
1.1. GENERAL DESCRIPTION	3
1.2. APPLICATIONS	4
1.3. ORDERING INFORMATION	5
2. BLOCK DIAGRAM	6
2.1. PINOUT	6
2.2. PIN DESCRIPTION	6
3. ELECTRICAL SPECIFICATIONS	7
3.1. ABSOLUTE MAXIMUM RATINGS	7
3.2. OPERATING PARAMETERS	8
3.3. OSCILLATOR PARAMETERS	9
4. PACKAGE	10
4.1. DIMENSIONS	10
4.1.1. THD PACKAGE (STANDARD)	10
4.1.2. SMD PACKAGE	11
4.1.3. RECOMMENDED SOLDER PAD LAYOUT FOR SMD PACKAGE	11
4.2. MARKING AND PIN #1 INDEX	12
5. MATERIAL COMPOSITION DECLARATION & ENVIRONMENTAL INFORMATION	13
5.1. HOMOGENOUS MATERIAL COMPOSITION DECLARATION	13
5.2. RECYCLING MATERIAL INFORMATION	14
5.3. ENVIRONMENTAL PROPERTIES & ABSOLUTE MAXIMUM RATINGS	15
6. APPLICATION INFORMATION	16
6.1. TEST CIRCUIT	16
6.2. SOLDERING INFORMATION	16
6.3. HANDLING PRECAUTIONS FOR MODULES WITH EMBEDDED CRYSTALS	17
7. COMPLIANCE INFORMATION	18
8. DOCUMENT REVISION HISTORY	18

OCXOS

Standard OCXO with Sine Wave Output – up to 54 MHz

1. OVERVIEW

- Oven Controlled Oscillator with built-in oven and AT-cut crystal (OCXO), operating in fundamental mode
- Frequency stability versus operating temperature range: ($V_{DD} = 5.0\text{ V}$)
 - $\pm 75\text{ ppb}$ at A = 0 to $+60^\circ\text{C}$
 - $\pm 150\text{ ppb}$ at B = -20 to $+70^\circ\text{C}$
 - $\pm 250\text{ ppb}$ at C = -40 to $+85^\circ\text{C}$
 - $\pm 300\text{ ppb}$ at E = -55 to $+85^\circ\text{C}$
- Frequency long term aging ($F < 40\text{ MHz}$):
 - long term aging 10 years $< \pm 3\text{ ppm}$
 - long term aging 1st year $< \pm 0.5\text{ ppm}$
- Minimum frequency control range by V_C or R ($F < 40\text{ MHz}$): $\geq \pm 3\text{ ppm}$
- Very fast start-up: typ. 1 ms at 25°C
- Fast warm-up. Warm-up time within $\pm 0.1\text{ ppm}$ at $+25^\circ\text{C}$:
 - $\leq 120\text{ s}$, $V_{DD} = 3.3\text{ V}$
 - $\leq 60\text{ s}$, $V_{DD} = 5.0\text{ V}$
- Output signal sine wave (load = $50\ \Omega$)
- High shock and vibration resistance
- Operating voltage: 3.3 V or 5.0 V
- Power consumption at $+25^\circ\text{C}$:
 - $\leq 120\text{ mA}$, $V_{DD} = 3.3\text{ V}$
 - $\leq 80\text{ mA}$, $V_{DD} = 5.0\text{ V}$
- Operating temperature range:
 - A = 0 to $+60^\circ\text{C}$
 - B = -20 to $+70^\circ\text{C}$
 - C = -40 to $+85^\circ\text{C}$
 - E = -55 to $+85^\circ\text{C}$ (only available at 5.0 V version (V))
 - X = Custom
- Low aging rate
- DIL-14 metal package (20.2 x 12.6 mm), RoHS-compliant

1.1. GENERAL DESCRIPTION

The OCXOS combines an Oven Controlled Sine Wave Output oscillator circuitry together with an AT-cut quartz crystal in a hermetically sealed DIL-14 / 4 pins metal package. No external components are required.

The frequency output – up to 54 MHz on F_{OUT} pin is always enabled. The frequency can be adjusted by varying the control voltage on V_C pin (version V3 or V5) or by varying the resistance R_C between V_C pin and GND (version R1).

1.2. APPLICATIONS

The OCXOS oven controlled clock oscillator module combines outstanding performance and robustness in a standard metal package:

- OCXOS oscillator module (embedded XTAL) in a standard 20.2 x 12.6 mm DIL-14 / 4 pins metal package
- High shock and vibration resistant

The robust construction and high performances make this product perfectly suitable for many high reliability applications:

- Avionics / Aerospace: On-Board Computers and Instruments
- Instrumentation: Field and Laboratory Test Equipment
- Network Synchronization: Wireless Base Stations (3G, 4G and 5G) / SONET / SDH / OTN / SyncE / IEEE 1588 / VSAT / GNSS Time Synchronization
- Digital Broadcasting: DAB / DVB
- Battery Powered Monitoring Devices: Remote/Smart Metering Devices / Standalone Stations (Weather/Environment) / IoT

1.3. ORDERING INFORMATION

Example: OCXOS W – C V3 20.000 MHz D2 XXX

Code	Package Size
OCXOS	20.2 x 12.6 mm

Code	Supply voltage
W	$V_{DD} = 3.3 \text{ V}$
V	$V_{DD} = 5.0 \text{ V}$

Code	Temperature range
A	0 to +60°C
B	-20 to +70°C
C	-40 to +85°C
E	-55 to +85°C *
X	Custom

Code	Frequency control
R1	$R = 0 \text{ to } 10 \text{ k}\Omega$
V3	$V_C = 0 \text{ to } 3.3 \text{ V}$
V5	$V_C = 0.5 \text{ to } 5.0 \text{ V}$
YA	Internal accuracy $\leq \pm 1.0 \text{ ppm}$
YB	Internal accuracy $\leq \pm 0.5 \text{ ppm}$
Y	Custom

Code	Frequency
20.000 MHz	20.000 MHz

Code	Option 1
D2	SMD (formed leads)
Blank	THD (Standard)

Code	Customer specification N°
XXX	XXX

* E version is only available at 5.0 V version (V).

2. BLOCK DIAGRAM

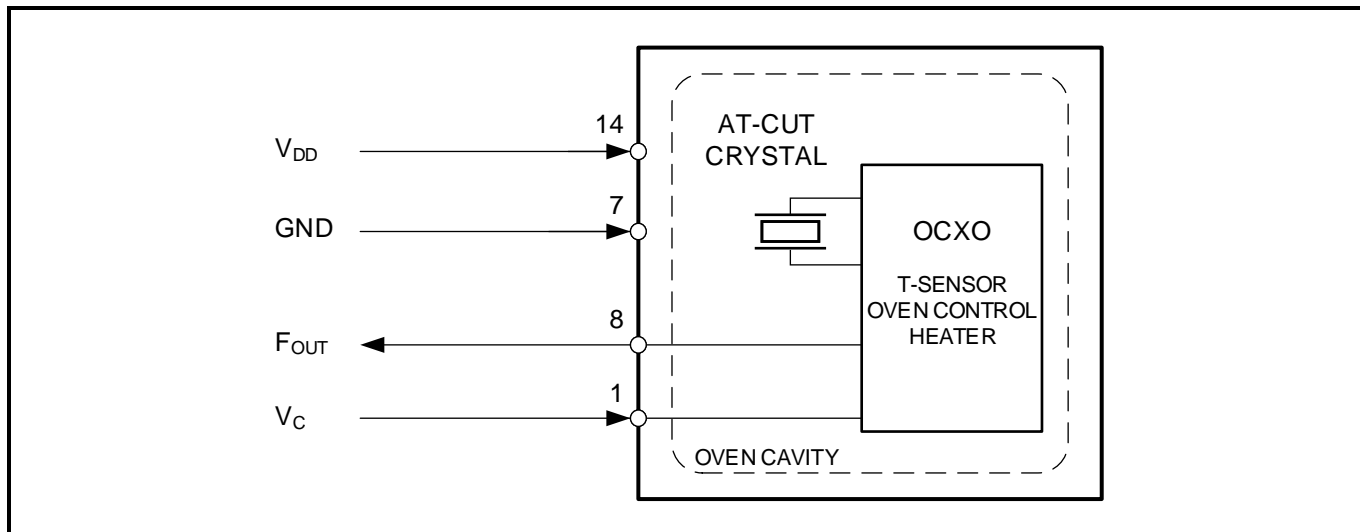

2.1. PINOUT

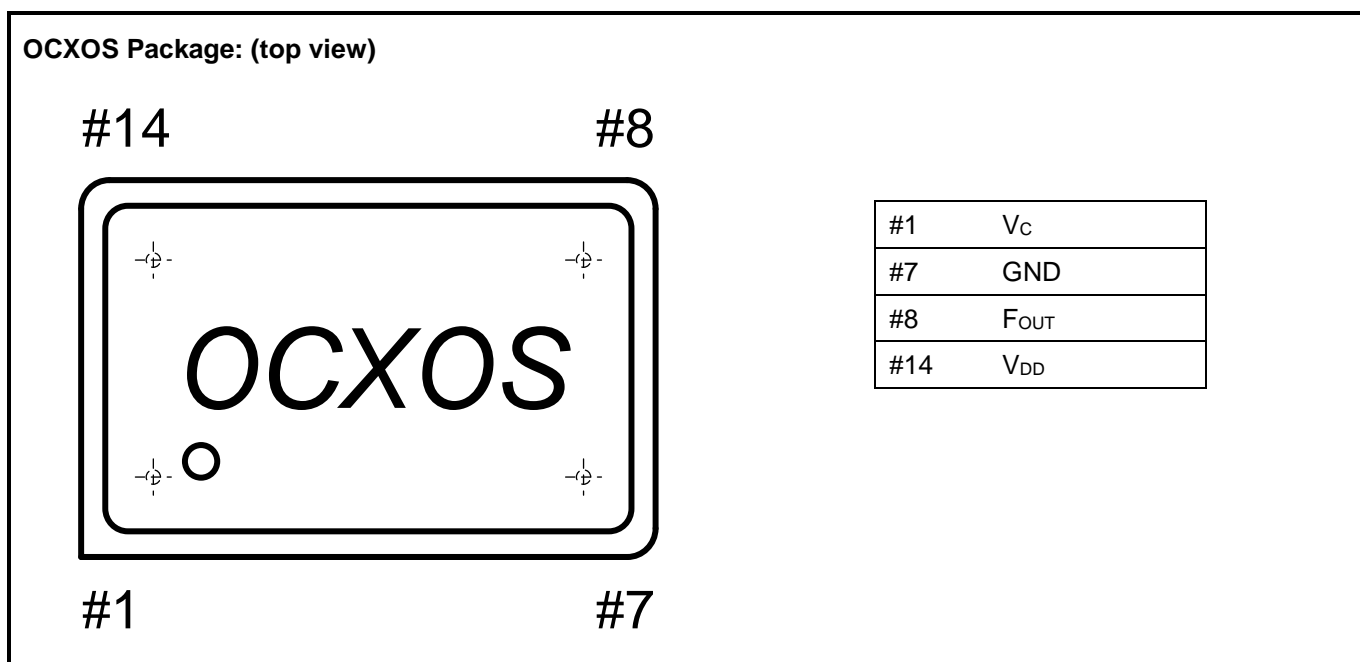

2.2. PIN DESCRIPTION

Symbol	Pin #	Description
V_C	1	Control Voltage Input. The frequency on F_{OUT} pin can be adjusted by varying the voltage applied to V_C pin (version V3 or V5) or by varying the resistance R_C between V_C pin and GND (version R1). The slope polarity is positive (increasing voltage/resistance increases output frequency). If there is no frequency control (YA or YB), V_C pin has to be connected to GND.
GND	7	Ground.
F_{OUT}	8	Clock Output; always enabled. F_{OUT} pin drives the sine wave of the frequency. The frequency can be adjusted by varying the control voltage applied to the V_C pin (version V3 or V5) or by varying the resistance R_C between V_C pin and GND (version R1). If there is no frequency control (YA or YB), V_C pin has to be connected to GND.
V_{DD}	14	Power Supply Voltage.

3. ELECTRICAL SPECIFICATIONS

3.1. ABSOLUTE MAXIMUM RATINGS

Absolute Maximum Ratings according to IEC 60134:

SYMBOL	PARAMETER	CONDITIONS	MIN	MAX	UNIT
V _{DD}	Power supply voltage	Nominal V _{DD} = 3.3 V	-0.3	3.8	V
		Nominal V _{DD} = 5.0 V	-0.3	5.5	
V _I	Input voltage		-0.3	V _{DD}	V
V _O	Output voltage		-0.3	V _{DD}	V
V _{ESD}	ESD voltage	HBM (1)		±2000	V
		MM (2)		±200	
T _A	Operating temperature range A		0	60	°C
T _B	Operating temperature range B		-20	70	°C
T _C	Operating temperature range C		-40	85	°C
T _E	Operating temperature range E		-55	85	°C
T _{STO}	Storage temperature	Stored as bare product	-55	125	°C
T _{PEAK}	Maximum pins soldering temperature	10 seconds maximum		235	°C
		5 seconds maximum		260	

(1) HBM: Human Body Model, according to JESD22-A114.

(2) MM: Machine Model, according to JESD22-A115.

3.2. OPERATING PARAMETERS

For this Table, V_{DD} = nominal voltage; $GND = 0\text{ V}$; $T_A = +25^\circ\text{C}$; unless otherwise indicated.

Operating Parameters:

SYMBOL	PARAMETER	CONDITIONS	MIN	TYP	MAX	UNIT
Supply						
V_{DD}	Power supply voltage (1)	Nominal $V_{DD} = 3.3\text{ V}$	3.15		3.45	V
		Nominal $V_{DD} = 5.0\text{ V}$	4.8		5.2	
I_{DD}	Input current. $T_A = +25^\circ\text{C}$, $R_L = 50\ \Omega$	Nominal $V_{DD} = 3.3\text{ V}$			120	mA
		Nominal $V_{DD} = 5.0\text{ V}$			80	
	Input current. $T_A = -20^\circ\text{C}$, $R_L = 50\ \Omega$	Nominal $V_{DD} = 3.3\text{ V}$			170	
		Nominal $V_{DD} = 5.0\text{ V}$			120	
	Input current at start-up. $T_A = +25^\circ\text{C}$, $R_L = 50\ \Omega$	Nominal $V_{DD} = 3.3\text{ V}$, duration = 30 seconds			350	
		Nominal $V_{DD} = 5.0\text{ V}$, duration = 10 seconds			300	
Input pin 1 V_C (Version V3 or V5)						
V_C	Control voltage range	Version V3	0		3.3	V
		Version V5	0.5		5.0	
	Slope polarity		Positive			
Z_{VC}	V_C input impedance		47			k Ω
Input pin 1 V_C (Version R1)						
R_C	Control resistor range (2)		0		10	k Ω
		Slope polarity	Positive			
Z_{VC}	V_C input impedance		-4.7			k Ω
Input pin 1 V_C (Version YA or YB)						
	No frequency control		Pin V_C has to be connected to GND			
Output F_{OUT} (Sine Wave)						
R_L	Output load resistance		47.5	50	52.5	Ω
L_P (dBm)	Output power level, $F \leq 20\text{ MHz}$	Nominal $V_{DD} = 3.3\text{ V}$	2			dBm
		Nominal $V_{DD} = 5.0\text{ V}$	4			
	Output power level, $F > 20\text{ MHz}$	Nominal $V_{DD} = 3.3\text{ V}$	-2			
		Nominal $V_{DD} = 5.0\text{ V}$	0			
$P_S - P_C$	Harmonics				-10	dBc
	Spurious				-70	
(1) A 3.3 μF buffer and a 47 nF decoupling capacitor have to be connected between V_{DD} and GND close to the device.						
(2) Resistor R_C between pin V_C and GND						

3.3. OSCILLATOR PARAMETERS

For this Table, V_{DD} = nominal voltage; GND = 0 V; T_A = +25°C; unless otherwise indicated.

Oscillator Parameters:

SYMBOL	PARAMETER	CONDITIONS	MIN	TYP	MAX	UNIT
General						
F	Frequency range		10		54	MHz
t_{START}	Oscillator start-up time			1	5	ms
Frequency Characteristics						
$\Delta F/F$	Frequency versus temperature (without air flow) (see ORDERING INFORMATION)	$V_{DD} = 3.3 V \pm 0.15 V$, A = 0 to +60°C B = -20 to +70°C C = -40 to +85°C			± 75 ± 150 ± 250	ppb
		$V_{DD} = 5.0 V \pm 0.2 V$, A = 0 to +60°C B = -20 to +70°C C = -40 to +85°C E = -55 to +85°C			± 75 ± 150 ± 250 ± 300	
$\Delta F/F$	Frequency long term aging (1)	< 40 MHz long term aging 10 years long term aging 1 st year			< ± 3 ± 0.5	ppm
		≥ 40 MHz long term aging 10 years long term aging 1 st year			< ± 4 ± 1	
$\Delta F/F$	Minimum frequency control range by V_C or R_C , (see input pin 1 V_C in section OPERATING PARAMETERS)	< 40 MHz	± 3			ppm
		≥ 40 MHz	± 4			
$\Delta F/F$	Frequency stability versus load change of $\pm 5\%$	< 40 MHz			± 10	ppb
		≥ 40 MHz			± 30	
t	Warm-up time within ± 0.1 ppm at +25°C	Nominal $V_{DD} = 3.3 V$			120	s
		Nominal $V_{DD} = 5.0 V$			60	s
$\Delta F/F$	Stability versus V_{DD}				< ± 0.1	ppm
σ	Short term stability (Allan deviation) at T = 0.1 to 30 s				< 0.5	ppb
	Typical short term stability (Allan deviation) at T = 1 s			0.05		
L	Phase noise	Typical at 10 MHz: Static conditions, BW = 1 Hz	10 Hz 100 Hz 1 kHz 10 kHz 100 kHz		-110 -135 -145 -150 -150	dBc/Hz

(1) After 30 days operating.

4. PACKAGE

4.1. DIMENSIONS

4.1.1. THD PACKAGE (STANDARD)

OCXOS THD standard package (Option 1 = Blank):

Package dimensions (bottom view):

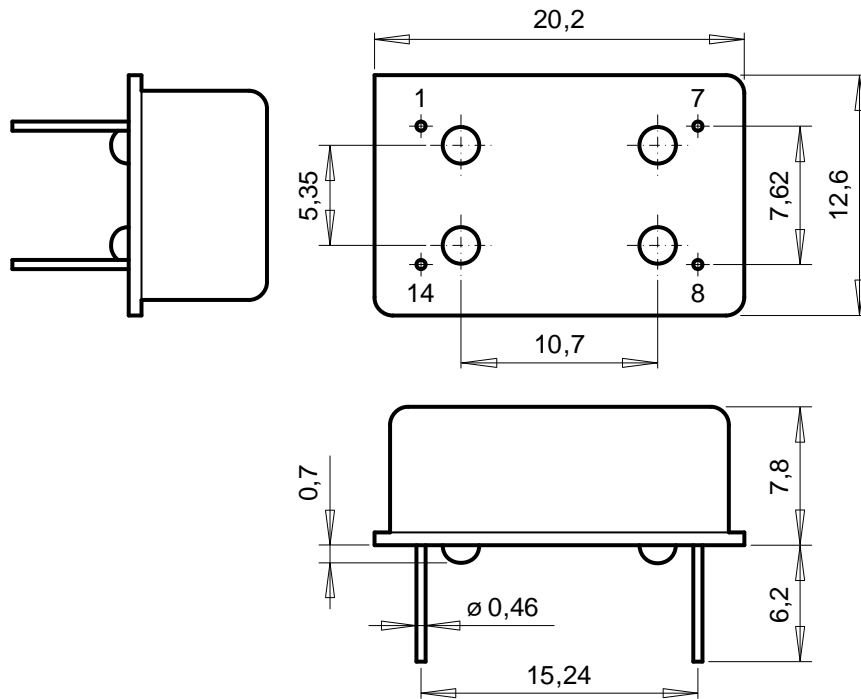

Case is connected to GND (pin 7)

Dimensions: in mm
 Tolerances: unless otherwise specified ± 0.1 mm
 Drawing: OCXOS_THD_Pack-drw_20211015

4.1.2.SMD PACKAGE

OCXOS SMD formed leads package (Option 1 = D2):

Package dimensions (bottom view):

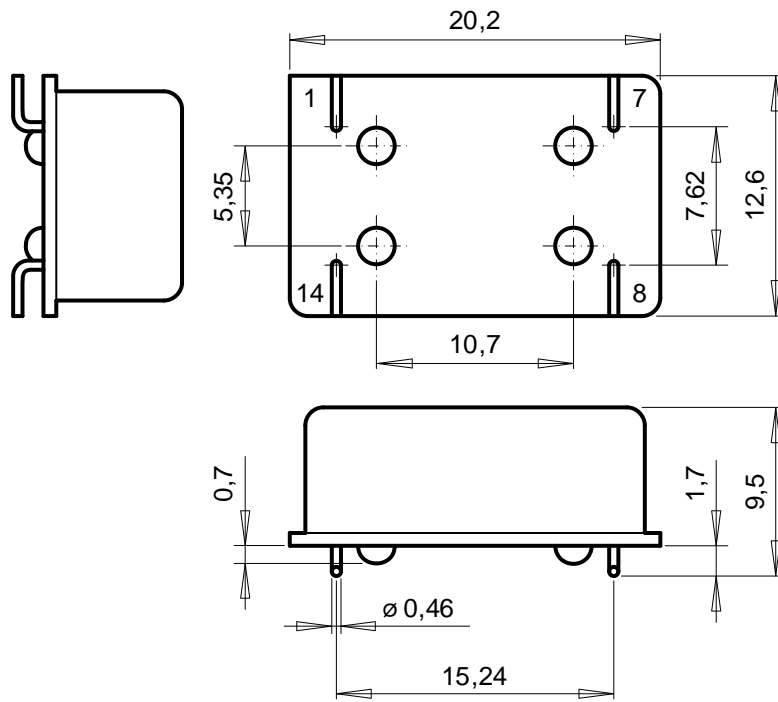

Case is connected to GND (pin 7)

Dimensions: in mm
 Tolerances: unless otherwise specified ± 0.1 mm
 Drawing: OCXOS_SMD_Pack-drw_20211015

4.1.3.RECOMMENDED SOLDER PAD LAYOUT FOR SMD PACKAGE

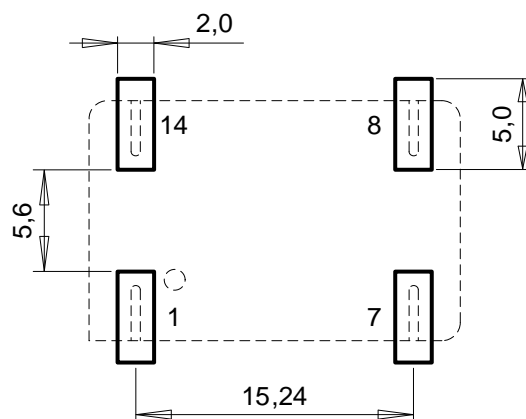

Dimensions: in mm

4.2. MARKING AND PIN #1 INDEX

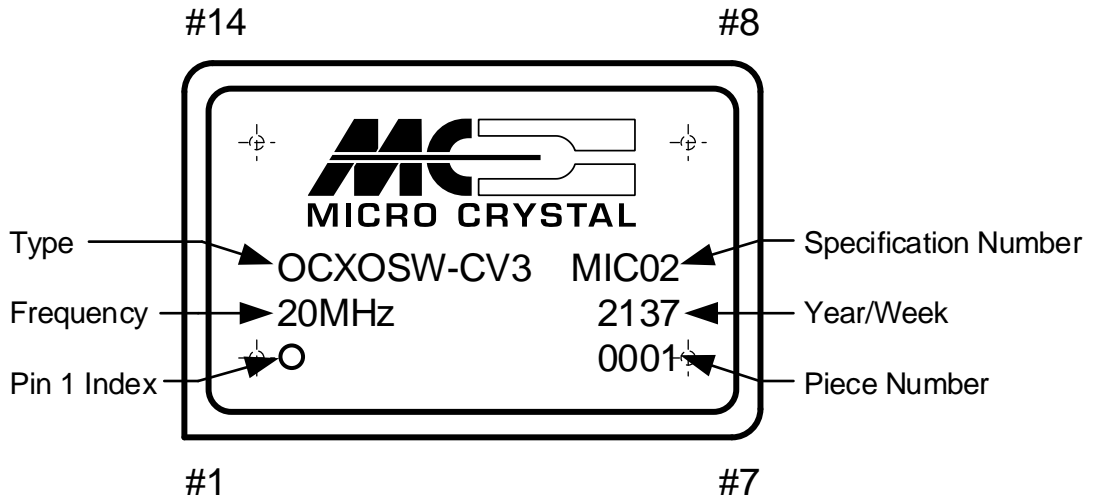

Laser marking OCXOS Package: (top view)



5. MATERIAL COMPOSITION DECLARATION & ENVIRONMENTAL INFORMATION

5.1. HOMOGENOUS MATERIAL COMPOSITION DECLARATION

Homogenous material information according to IPC-1752 standard

Material Composition OCXOS:								
No.	Item Component Name	Sub Item Material Name	Material Weight		Substance Element	CAS Number	Comment	
			(mg)	(%)				
1	Resonator	Quartz Crystal	9	100%	SiO ₂	14808-60-7		
2	Electrodes	Cr+Au	1	5%	Cr	Cr: 7440-47-3		
				95%	Au	Au: 7440-57-5		
3	Resonator Housing	Ceramic Terminations	125	90%	Al ₂ O ₃	1344-28-1		
				7%	W	W: 7440-33-7	Tungsten	
				2%	Ni	Ni: 7440-02-0	Nickel plating	
				1%	Au	Au: 7440-57-5	Gold plating	
4	Resonator Lid	Kovar Lid	65	90%	Fe53Ni29Co18	Fe: 7439-89-6 Ni: 7440-02-0 Co: 7440-48-4	Metal Lid (Kovar)	
				9%	Ni	Ni: 7440-02-0	Nickel plating	
		1%		Au	Au: 7440-57-5	Gold plating		
				Ni-plating Au-plating				
5	Resonator Seal	Solder Preform	10	80%	Au80 / Sn20	Au: 7440-57-5		
20%	Sn	Sn: 7440-31-5						
6	Resistors	Ceramic body Terminations	60	90%	Al ₂ O ₃	1344-28-1		
				1%	Cu	Cu: 7440-50-8		
				1%	Ni	Ni: 7440-02-0		
				8%	Sn	Sn: 7440-31-5		
7	Solder connections	Solder	50	100%	Sn97Ag2Cu1	Sn: 7440-31-5 Ag: 7440-22-4 Cu: 7440-50-8		
8	PCB	Substrate Plating	780	80%	Fiberglass Epoxy			
				14%	Cu	Cu: 7440-50-8		
				3%	Ni	Ni: 7440-02-0		
				3%	Au	Au: 7440-57-5		
9	Custom IC	Silicon Die pad plating Bonding wires	120	90%	Si	Si: 7440-21-3		
				1%	Al	Al: 7429-90-5		
				9%	Au	Au: 7440-57-5		
10	Base	CRS1010 Steel	2350	94%	Fe	Fe: 7439-89-6		
		Kovar Pins		3%	Fe53Ni29Co18	Fe: 7439-89-6 Ni: 7440-02-0 Co: 7440-48-4	Metal Pins (Kovar)	
		Glass		3%		65997-17-3		
11	Cap	SPCD Steel	1250	100%	Fe	Fe: 7439-89-6		
12	Capacitors	Ceramic body Terminations	120	90%	Al ₂ O ₃	1344-28-1		
				1%	Cu	Cu: 7440-50-8		
				1%	Ni	Ni: 7440-02-0		
				8%	Sn	Sn: 7440-31-5		
13	Conductive adhesive	Silver filled Epoxy	60	70%	Ag	Ag: 7440-22-4		
				30%	EP	129915-35-1		
		Unit weight typ. ±20%	5000					

5.2. RECYCLING MATERIAL INFORMATION

Recycling material information according to IPC-1752 standard.

Element weight is accumulated and referenced to the unit weight of 5000 mg.

Item Material Name	No.	Item Component Name	Material Weight		Substance Element	CAS Number	Comment
			(mg)	(%)			
Quartz Crystal	1	Resonator	9.0	0.18	SiO ₂	14808-60-7	
Chromium	2	Electrodes	0.05	0.001	Cr	Cr: 7440-47-3	
Ceramic	3a 6a 12a	Resonator Housing Resistors Capacitors	274.5	5.49	Al ₂ O ₃	1344-28-1	
Gold	2 3d 4c 5 8d 9c	Electrodes Resonator Housing Resonator Lid Resonator Seal PCB Custom IC	45.0	0.90	Au	Au: 7440-57-5	
Tin	5 6d 12d	Resonator Seal Resistors Capacitors	16.4	0.33	Sn	Sn: 7440-31-5	
Nickel	3c 4b 6c 8c 12c	Resonator Housing Resonator Lid Resistors PCB Capacitors	33.6	0.67	Ni	Ni: 7440-02-0	
Tungsten	3b	Resonator Housing	8.75	0.175	W	W: 7440-33-7	
Kovar	4a 10b	Resonator Lid Base	129.0	2.58	Fe53Ni29Co18	Fe: 7439-89-6 Ni: 7440-02-0 Co: 7440-48-4	
Iron	10a 11	Base Cap	3459.0	69.18	Fe	Fe: 7439-89-6	
Glass	10c	Base	70.5	1.41		65997-17-3	
Copper	6b 8b 12b	Resistors PCB Capacitors	111.0	2.22	Cu	Cu: 7440-50-8	
Silicon	9a	Custom IC	108.0	2.16	Si	Si: 7440-21-3	
Aluminum	9b	Custom IC	1.2	0.024	Al	Al: 7429-90-5	
Silver	13	Conductive adhesive	42.0	0.84	Ag	Ag: 7440-22-4	
Epoxy	13	Conductive adhesive	18.0	0.36	EP	129915-35-1	
Substrate	8a	PCB	624.0	12.48	Fiberglass Epoxy		
Solder	7	Solder connections	50.0	1.0	Sn97Ag2Cu1	Sn: 7440-31-5 Ag: 7440-22-4 Cu: 7440-50-8	
Unit weight (total) typ. ±20%			5000	100			

5.3. ENVIRONMENTAL PROPERTIES & ABSOLUTE MAXIMUM RATINGS

Package	Description
DIL-14 / 4 pins metal package	Dual In-Line (DIL), hermetically sealed metal package.

Parameter	Directive	Conditions	Value
Product weight (total)			5000 mg
Storage temperature		Store as bare product	-55 to +125°C
Moisture sensitivity level (MSL)	IPC/JEDEC J-STD-020D		MSL1

6. APPLICATION INFORMATION

6.1. TEST CIRCUIT

Test circuit sine wave:

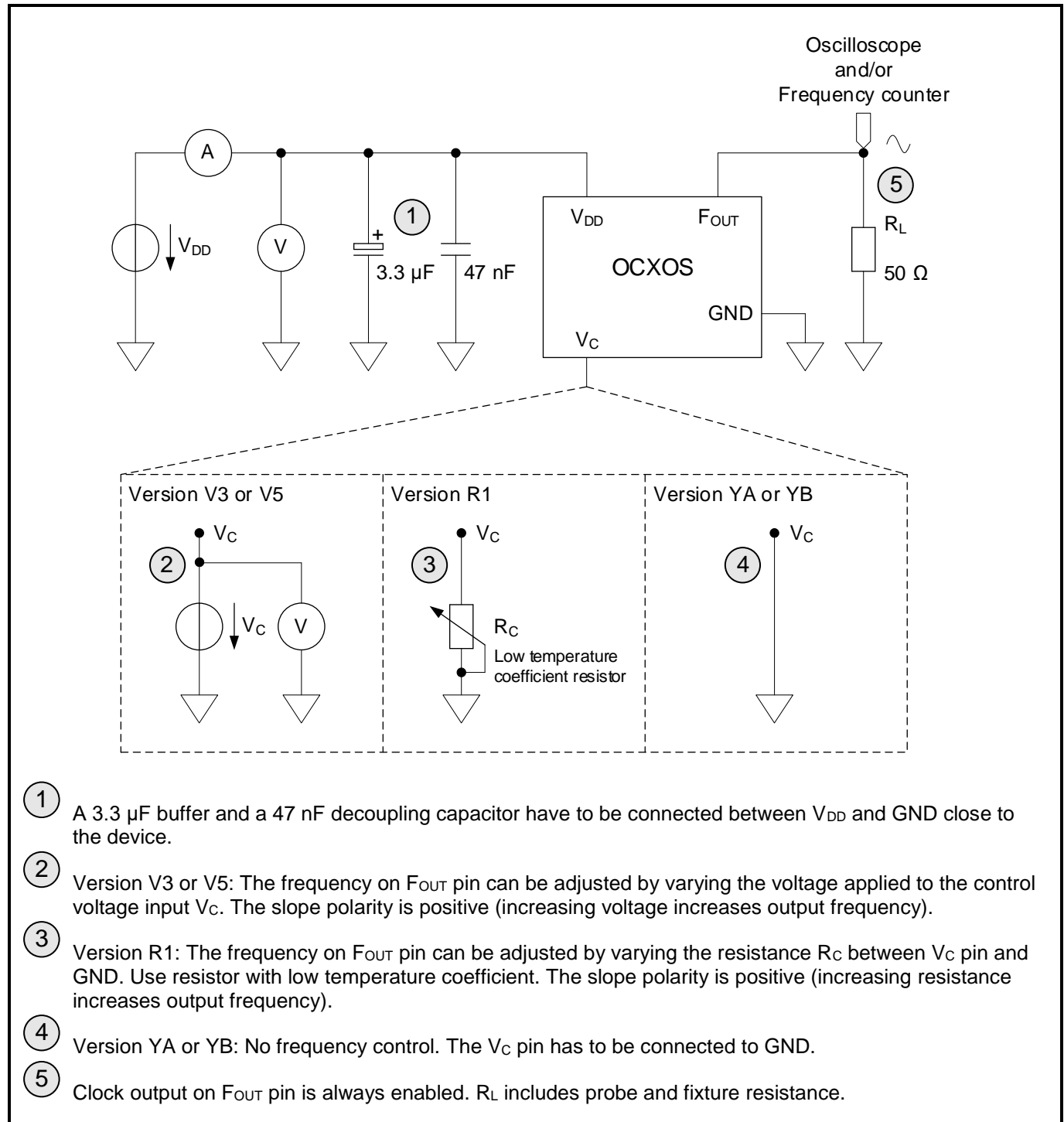

6.2. SOLDERING INFORMATION

Hand solder only – not reflow compatible. See ABSOLUTE MAXIMUM RATINGS.

6.3. HANDLING PRECAUTIONS FOR MODULES WITH EMBEDDED CRYSTALS

The built-in AT-cut crystal consists of pure Silicon Dioxide in crystalline form. The cavity in the built-in crystal package is evacuated and hermetically sealed in order for the crystal blank to function undisturbed from air molecules, humidity and other influences.

Shock and vibration:

Keep the crystal / module from being exposed to **excessive mechanical shock and vibration**. Micro Crystal guarantees that the crystal / module will bear a mechanical shock of 5000 g / 0.3 ms.

The following special situations may generate either shock or vibration:

Multiple PCB panels - Usually at the end of the pick & place process the single PCBs are cut out with a router. These machines sometimes generate vibrations on the PCB that have a fundamental or harmonic frequency close to the resonance frequency of the crystal unit. This might cause breakage of crystal blanks due to resonance. Router speed should be adjusted to avoid resonant vibration.

Ultrasonic cleaning - Avoid cleaning processes using ultrasonic energy. These processes can damage the crystals due to the mechanical resonance frequencies of the crystal blank.

Overheating, rework high temperature exposure:

Avoid overheating the package. The built-in crystal package is sealed with a seal ring consisting of 80% Gold and 20% Tin. The eutectic melting temperature of this alloy is at 280°C. Heating the seal ring up to >280°C will cause melting of the metal seal which then, due to the vacuum, is sucked into the cavity forming an air duct. This happens when using hot-air-gun set at temperatures >280°C.

7. COMPLIANCE INFORMATION

Micro Crystal confirms that the standard product Oven Controlled Oscillator OCXOS is compliant with “EU RoHS Directive” and “EU REACH Directives”.

Please find the actual Certificate of Conformance for Environmental Regulations on our website:

[CoC Environment OCXO-Series.pdf](#)

8. DOCUMENT REVISION HISTORY

Date	Revision #	Revision Details
November 2012	9.0	Initial version
February 2022	10.0	New extended version

The information contained in this document is believed to be accurate and reliable. However, Micro Crystal assumes no responsibility for any consequences resulting from the use of such information nor for any infringement of patents or other rights of third parties, which may result from its use. In accordance with our policy of continuous development and improvement, Micro Crystal reserves the right to modify specifications mentioned in this publication without prior notice and as deemed necessary.

Any use of Products for the manufacture of arms is prohibited. Customer shall impose that same obligation upon all third-party purchasers.

Without the express written approval of Micro Crystal, Products are not authorized for use as components in safety and life supporting systems as well as in any implantable medical devices. The unauthorized use of Products in such systems / applications / equipment is solely at the risk of the customer and such customer agrees to defend and hold Micro Crystal harmless from and against any and all claims, suits, damages, cost, and expenses resulting from any unauthorized use of Products.

No licenses to patents or other intellectual property rights of Micro Crystal are granted in connection with the sale of Micro Crystal products, neither expressly nor implicitly. In respect of the intended use of Micro Crystal products by customer, customer is solely responsible for observing existing patents and other intellectual property rights of third parties and for obtaining, as the case may be, the necessary licenses.



A COMPANY OF THE  SWATCH GROUP

Micro Crystal AG
Muehlestrasse 14
CH-2540 Grenchen
Switzerland

Phone +41 32 655 82 82
sales@microcrystal.com
www.microcrystal.com