

Product Documentation

CC8A-T1A Medical

**AT-Cut
Quartz Crystal Unit
24 MHz – 50 MHz**

2. Product Description

The CC8A-T1A Medical is a high frequency SMD Quartz Crystal Unit that incorporates an AT-Cut Quartz Crystal Resonator. The Quartz Crystal Resonator operates under vacuum condition in a hermetically sealed ceramic package with ceramic lid.

The CC8A-T1A Medical AT-Cut Crystal is manufactured specifically for use in implantable medical devices.

- Safe for Helium environment: Ceramic lid with gold-tin preform-seal for best long-term hermeticity and stability.
- Low profile (maximum height 0.60 mm), lightweight (4.2 mg)

Suitable oscillator-circuitries can operate the CC8A-T1A Medical Quartz Crystal Units in fundamental mode in the frequency range of 24 MHz – 50 MHz. For technical assistance for optimizing oscillator-circuitries please contact Micro Crystal under sales@microcrystal.com

2.1. Application Examples

Pacemakers
 Defibrillators
 Neurostimulators
 Cardiac Monitoring Devices
 Implantable Drug Delivery Pumps
 Infusion Pumps
 Cochlear Implants
 Smart Orthopedic Implants

2.2. Ordering Information

Example: CC8A-T1A* 24.000 MHz CL: 9.0 pF -30/+30ppm TM QM

Code	Pads
T1A	Au flashed pads
T2A	SnPb plated pads on request
T5A	ENEPIG plated pads

Code	Temperature range
TM	0 to +55°C
TX	Custom

Code	Qualification
QM	Medical Grade

* The term Medical does not appear in the ordering information. QM implies medical.

3. Electrical Characteristics

3.1. Equivalent Electrical Model

The Quartz Crystal Unit is a passive component with no polarity. The equivalent circuit of the quartz crystal at its fundamental resonance frequency is represented by the Equivalent Electrical Model:

Electrical Symbol:

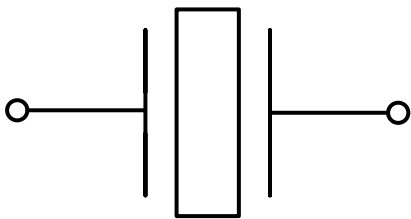

Equivalent Electrical Model:

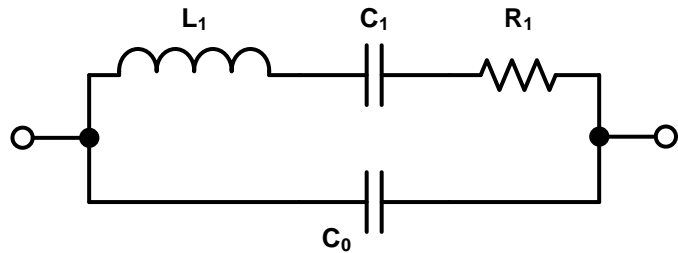

- L₁** Motional Inductance
- C₁** Motional Capacitance
- R₁** Motional Resistance (ESR)

- C₀** Static Capacitance (Shunt capacitance)

3.2. Frequency vs Temperature Characteristics

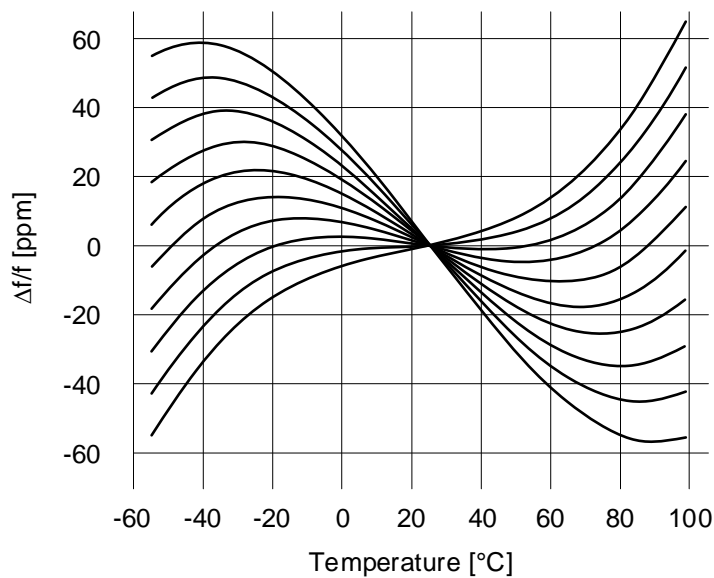

4. Mechanical Properties

4.1. Package Dimension

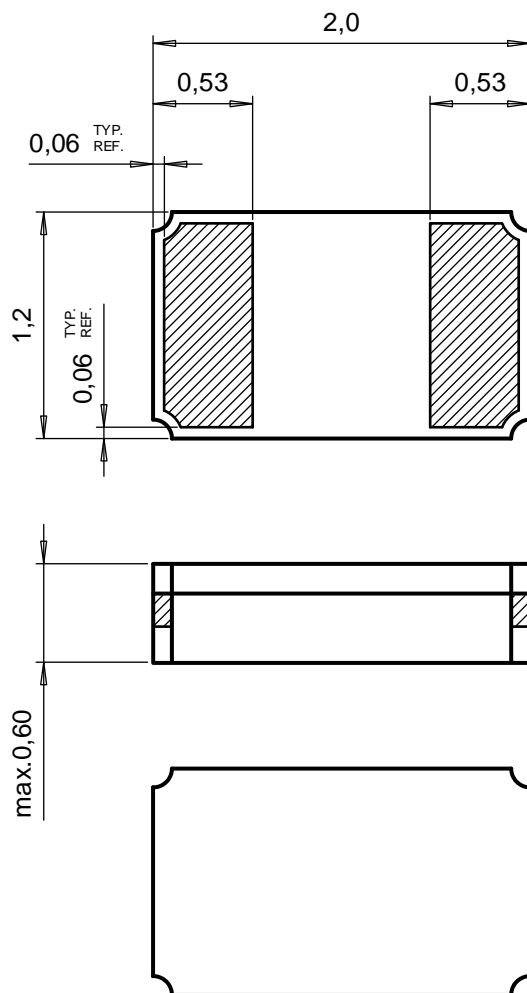

Tolerances: unless otherwise specified ± 0.1 mm
 Drawing: CC8A-T1A_Med_Pack-drw_20210128

4.2. Recommended Solderpad Layout

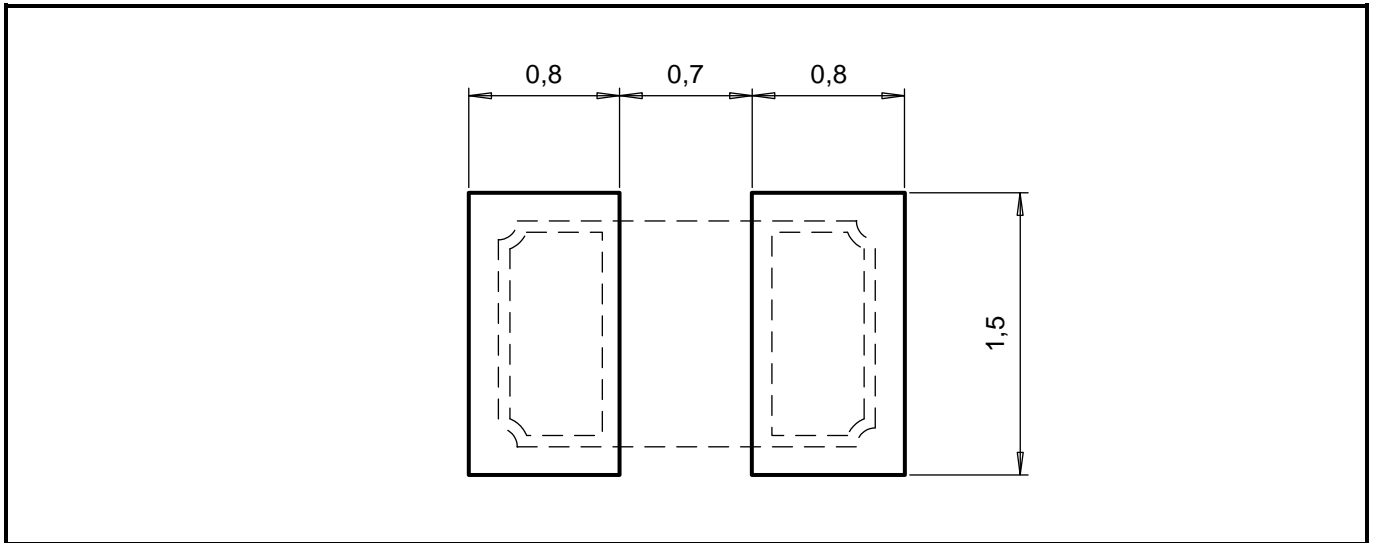

4.3. Product Marking

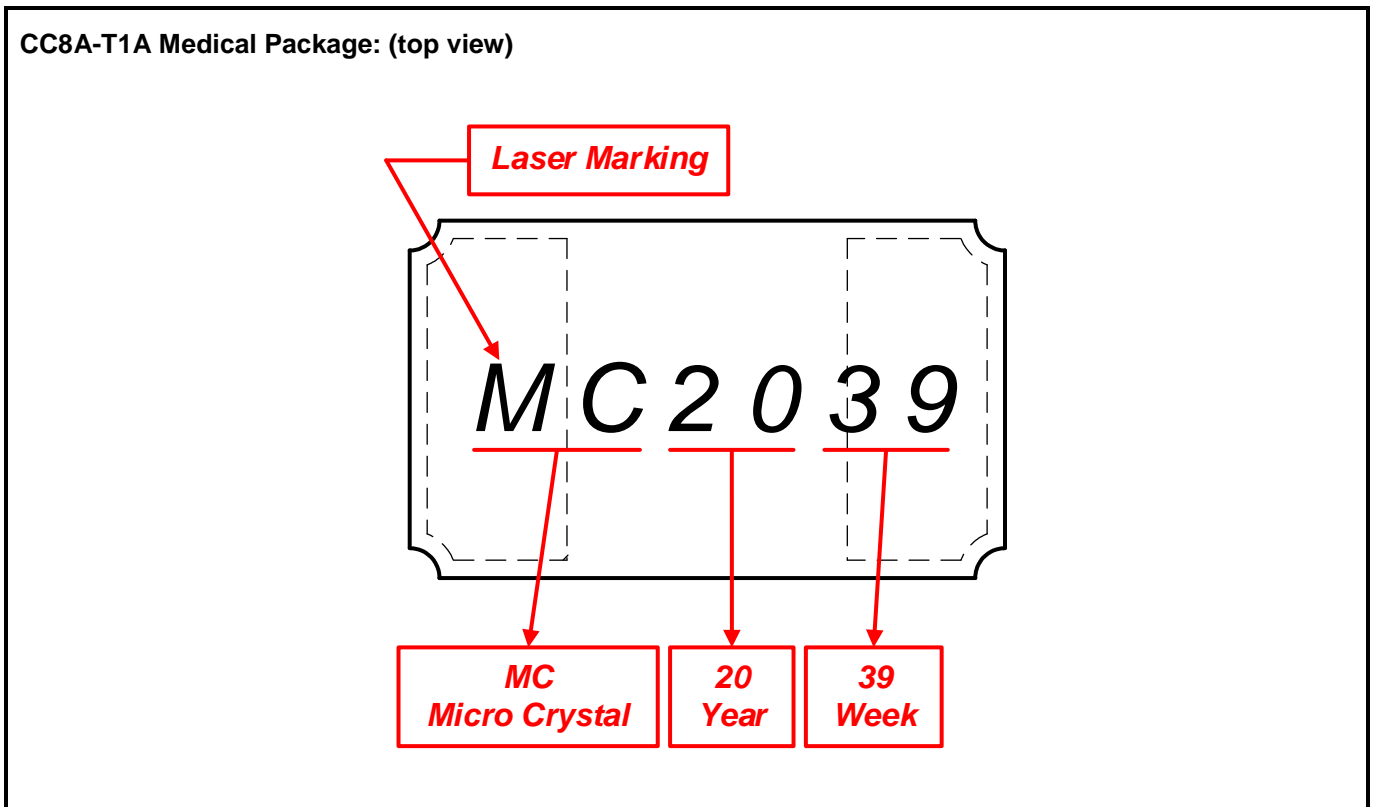

5. Material Composition Declaration & Environmental Information

5.1. Homogenous Material Composition Declaration

Homogenous material information according to IPC-1752 standard

Material Composition CC8A-T1A Medical:

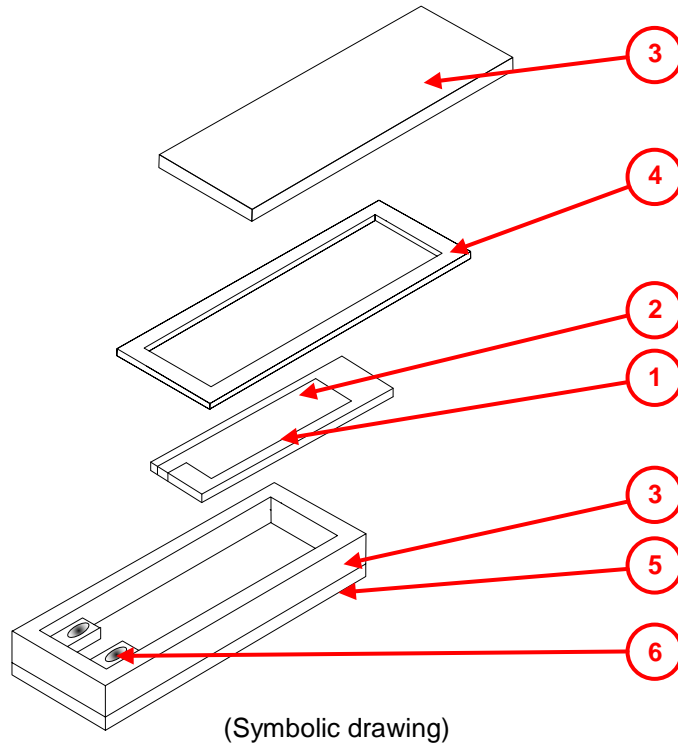

No.	Item Component Name	Sub Item Material Name	Material Weight		Substance Element	CAS Number	Comment
			(mg)	(%)			
1	Resonator	Quartz Crystal	0.22	100%	SiO ₂	14808-60-7	
2	Electrodes	Cr+Au	0.005	6%	Cr	7440-47-3	
				94%	Au	7440-57-5	
3	Housing	Ceramic	3.47	100%	Al ₂ O ₃	1344-28-1	
4	Seal	Solder Preform	0.18	80%	Au80 / Sn20	Au: 7440-57-5	
				20%		Sn: 7440-31-5	
5	Terminations	Internal and external terminals	0.30	80%	Mo	Mo: 7439-98-7	Molybdenum
				15%	Ni	Ni: 7440-02-0	Nickel plating
				5%	Au 0.5 micron	Au: 7440-57-5	Gold plating
6	Conductive adhesive	Silver filled glue	0.024	88%	Ag	Ag: 7440-22-4	
				12%	Glue		
		Unit weight typ. ±10%	4.2				

5.2. Material Analysis & Test Results

Homogenous material information according to IPC-1752 standard

No.	Item Component Name	Sub Item Material Name	RoHS						Halogen				Phthalates				
			Pb	Cd	Hg	Cr+6	PBB	PBDE	F	Cl	Br	-	BBP	DBP	DEHP	DINP	
1	Resonator	Quartz Crystal	nd	nd	nd	nd	nd	nd	nd	nd	nd	nd	nd	nd	nd	nd	nd
2	Electrodes	Cr+Au	nd	nd	nd	nd	nd	nd	nd	nd	nd	nd	nd	nd	nd	nd	nd
3	Housing	Ceramic	nd	nd	nd	nd	nd	nd	nd	nd	nd	nd	nd	nd	nd	nd	nd
4	Seal	Solder Preform	nd	nd	nd	nd	nd	nd	nd	nd	nd	nd	nd	nd	nd	nd	nd
5	Terminations	Int. & ext. terminals	nd	nd	nd	nd	nd	nd	nd	nd	nd	nd	nd	nd	nd	nd	nd
6	Conductive adhesive	Silver filled glue	nd	nd	nd	nd	nd	nd	nd	nd	nd	nd	nd	nd	nd	nd	nd
	MDL	Measurement Detection Limit	2 ppm			5 ppm			50 ppm				0.003%			0.01%	

nd = not detectable

Test methods:

RoHS	Test method with reference to IEC 62321-5: 2013	MDL: 2 ppm (PBB / PBDE: 5 ppm)
Halogen	Test method with reference to BS EN 14582:2007	MDL: 50 ppm
Phthalates	Test method with reference to EN 14372	MDL: 0.003 % (DINP 0.01%)

5.3. Recycling Material Information

Recycling material information according to IPC-1752 standard.

Element weight is accumulated and referenced to the unit weight of 4.2 mg.

Item Material Name	No.	Item Component Name	Material Weight		Substance Element	CAS Number	Comment
			(mg)	(%)			
Quartz Crystal	1	Resonator	0.22	5.24	SiO ₂	14808-60-7	
Chromium	2	Electrodes	0.0003	0.007	Cr	7440-47-3	
Ceramic	3	Housing	3.47	82.64	Al ₂ O ₃	1344-28-1	
Gold	2 4 5	Electrodes Seal Terminations	0.16	3.90	Au	7440-57-5	
Tin	4	Seal	0.036	0.86	Sn	Sn: 7440-31-5	
Nickel	5	Terminations	0.045	1.07	Ni	Ni: 7440-02-0	
Molybdenum	5	Terminations	0.24	5.72	Mo	Mo: 7439-98-7	
Silver	6a	Conductive adhesive	0.021	0.50	Ag	Ag: 7440-22-4	
Glue	6b	Conductive adhesive	0.003	0.07	Glue		
Unit weight (total) typ. ±10%			4.2	100			

5.4. Environmental Properties & Absolute Maximum Ratings

Package	Description
DFN-2 ceramic package	Dual Flat No Leads (DFN), hermetically sealed ceramic package with ceramic lid. Safe for Helium environment.

Parameter	Directive	Conditions	Value
Product weight (total)			4.2 mg
Storage temperature	MIL-O-55310	Store as bare product	-55 to +125°C
Moisture sensitivity level (MSL)	IPC/JEDEC J-STD-020D		MSL 1
FIT / MTBF			available on request

Terminal finishes:

Au flashed pads (T1A version):

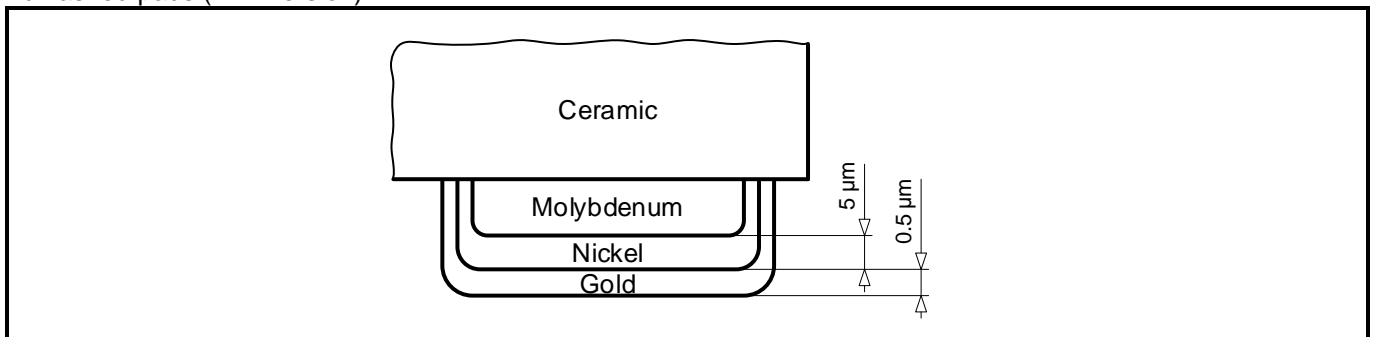

ENEPIG plated pads (T5A version):

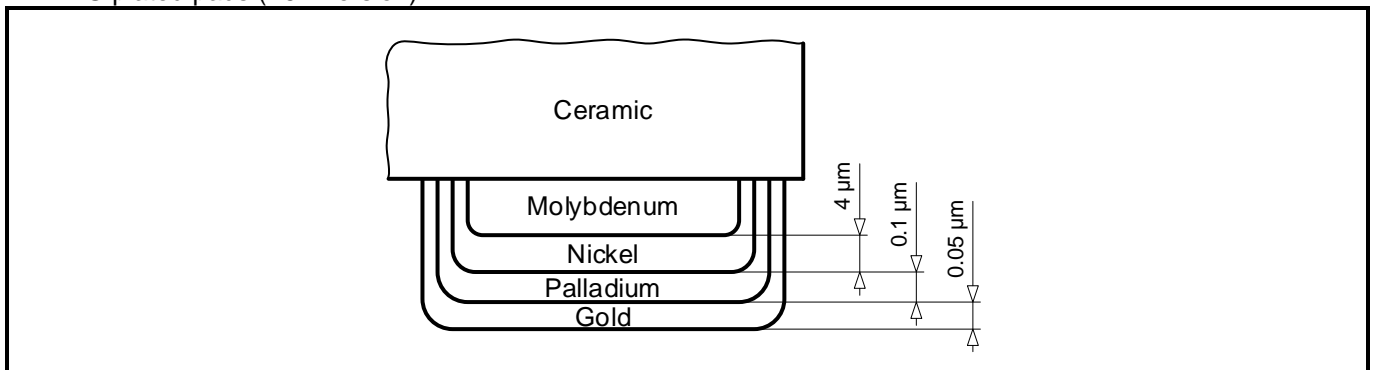

6. Application Information

6.1. Soldering Information

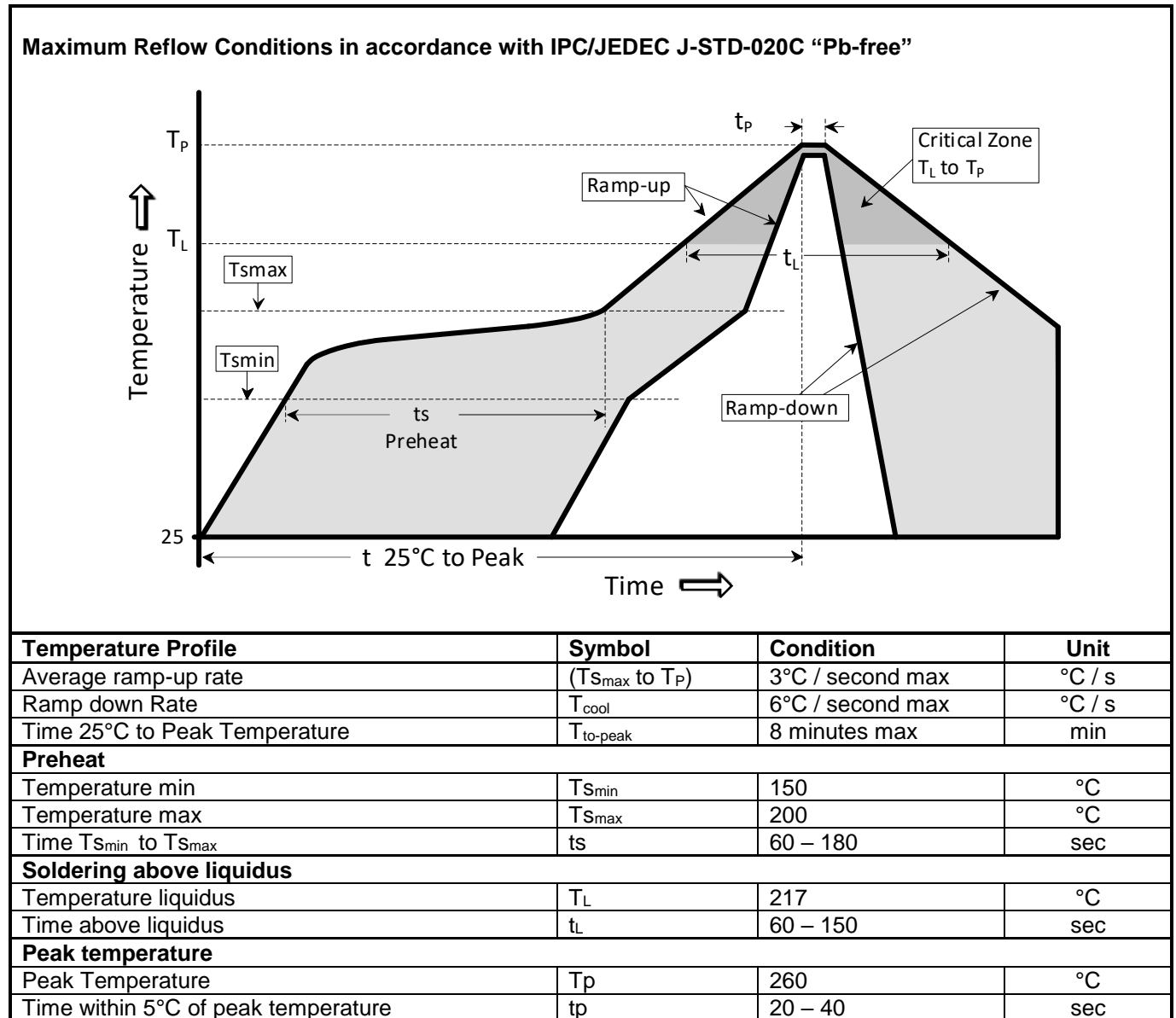

6.2. Handling Instructions for Quartz Crystal Units

The built-in AT-cut crystal consists of pure Silicon Dioxide in crystalline form. The cavity inside the package is evacuated and hermetically sealed in order for the crystal blank to function undisturbed from air molecules, humidity and other influences.

Shock and vibration:

Keep the crystal / module from being exposed to **excessive mechanical shock and vibration**. Micro Crystal guarantees that the crystal / module will bear a mechanical shock of 5000 g / 0.3 ms.

The following special situations may generate either shock or vibration:

Multiple PCB panels - Usually at the end of the pick & place process the single PCBs are cut out with a router. These machines sometimes generate vibrations on the PCB that have a fundamental or harmonic frequency close to the resonance frequency of the crystal unit. This might cause breakage of crystal blanks due to resonance. Router speed should be adjusted to avoid resonant vibration.

Ultrasonic cleaning - Avoid cleaning processes using ultrasonic energy. These processes can damage crystals due to mechanical resonance of the crystal blank.

Overheating, rework high temperature exposure:

Avoid overheating the package. The package is sealed with a seal ring consisting of 80% Gold and 20% Tin. The eutectic melting temperature of this alloy is at 280°C. Heating the seal ring up to >280°C will cause melting of the metal seal which then, due to the vacuum, is sucked into the cavity forming an air duct. This happens when using hot-air-gun set at temperatures >300°C.

Use the following methods for rework:

- Use a hot-air- gun set at 270°C.
- Use 2 temperature controlled soldering irons, set at 270°C, with special-tips to contact all solder-joints from both sides of the package at the same time, remove part with tweezers when pad solder is liquid.

7. Packing & Shipping Information

Reel: 7" = 178 mm

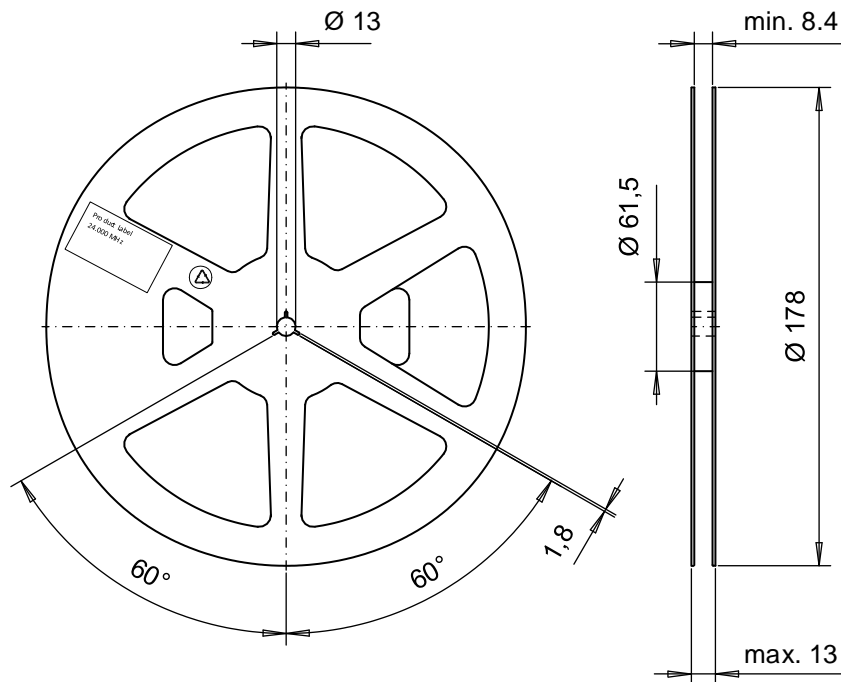

Carrier Tape:

Material: Polycarbonate

Width: 8 mm

Tape Leader and Trailer: Minimum length 300 mm

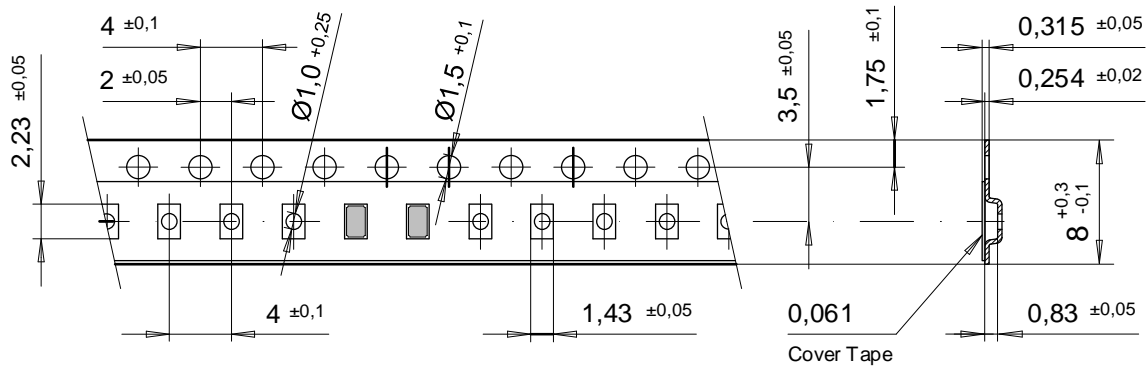

All dimensions are in mm
 CC8A-T1A_Med_Tape-drw_20210129

Cover Tape:

Tape: Polypropylene, 3M™ Universal Cover Tape (UCT)

Adhesive Type: Pressure sensitive, Synthetic Polymer

Thickness: 0.061 mm

Peel Method:

Medial section removal, both lateral stripes remain on carrier

8. Compliance Information

Micro Crystal confirms that the product Quartz Crystal Unit CC8A-T1A Medical is compliant with “EU RoHS Directive” and “EU REACH Directives”.

Please find the actual Certificate of Conformance for Environmental Regulations on our website:

[CoC Environment CC&CM-Series.pdf](#)

9. Document Revision History

Date	Revision #	Revision Details
February 2021	1.0	First release

The information contained in this document is believed to be accurate and reliable. However, Micro Crystal assumes no responsibility for any consequences resulting from the use of such information nor for any infringement of patents or other rights of third parties, which may result from its use. In accordance with our policy of continuous development and improvement, Micro Crystal reserves the right to modify specifications mentioned in this publication without prior notice and as deemed necessary.

Any use of Products for the manufacture of arms is prohibited. Customer shall impose that same obligation upon all third-party purchasers.

Without the express written approval of Micro Crystal, Products are not authorized for use as components in safety and life supporting systems as well as in any implantable medical devices. The unauthorized use of Products in such systems / applications / equipment is solely at the risk of the customer and such customer agrees to defend and hold Micro Crystal harmless from and against any and all claims, suits, damages, cost, and expenses resulting from any unauthorized use of Products.

No licenses to patents or other intellectual property rights of Micro Crystal are granted in connection with the sale of Micro Crystal products, neither expressly nor implicitly. In respect of the intended use of Micro Crystal products by customer, customer is solely responsible for observing existing patents and other intellectual property rights of third parties and for obtaining, as the case may be, the necessary licenses.



A COMPANY OF THE  SWATCH GROUP

Micro Crystal AG
Muehlestrasse 14
CH-2540 Grenchen
Switzerland

Phone +41 32 655 82 82
sales@microcrystal.com
www.microcrystal.com